

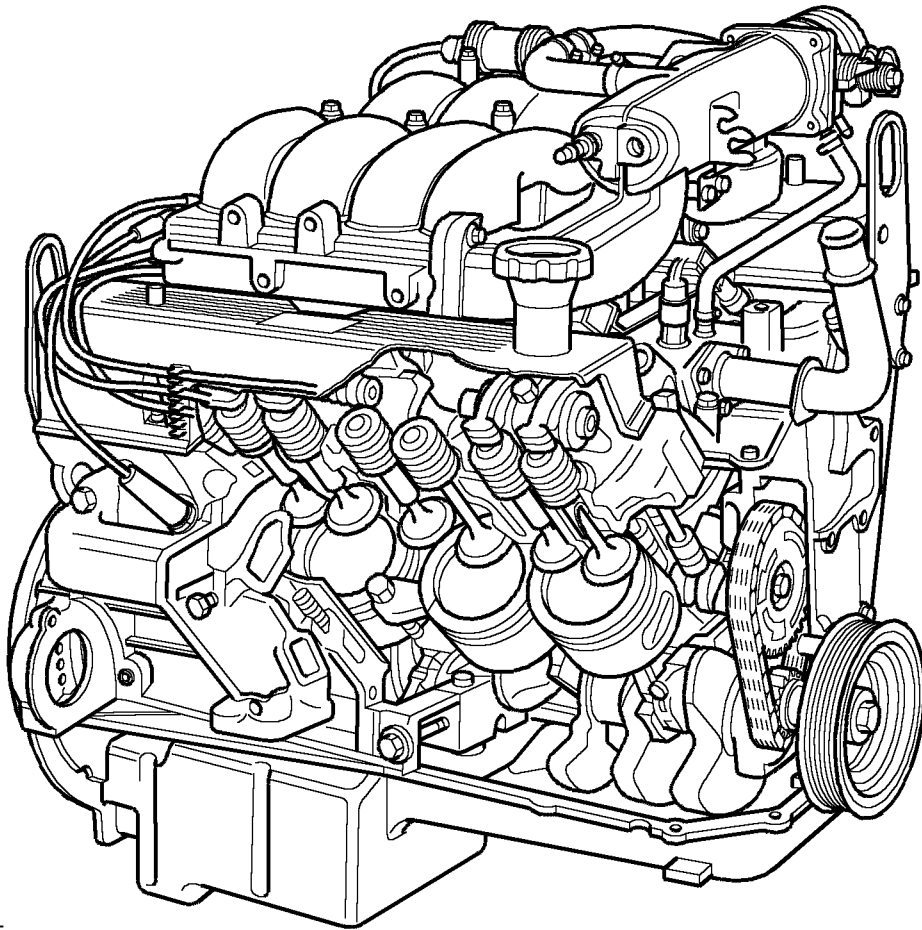

V8 ENGINE - from 99MY



M12 4965

CYLINDER HEAD COMPONENTS - from 99MY

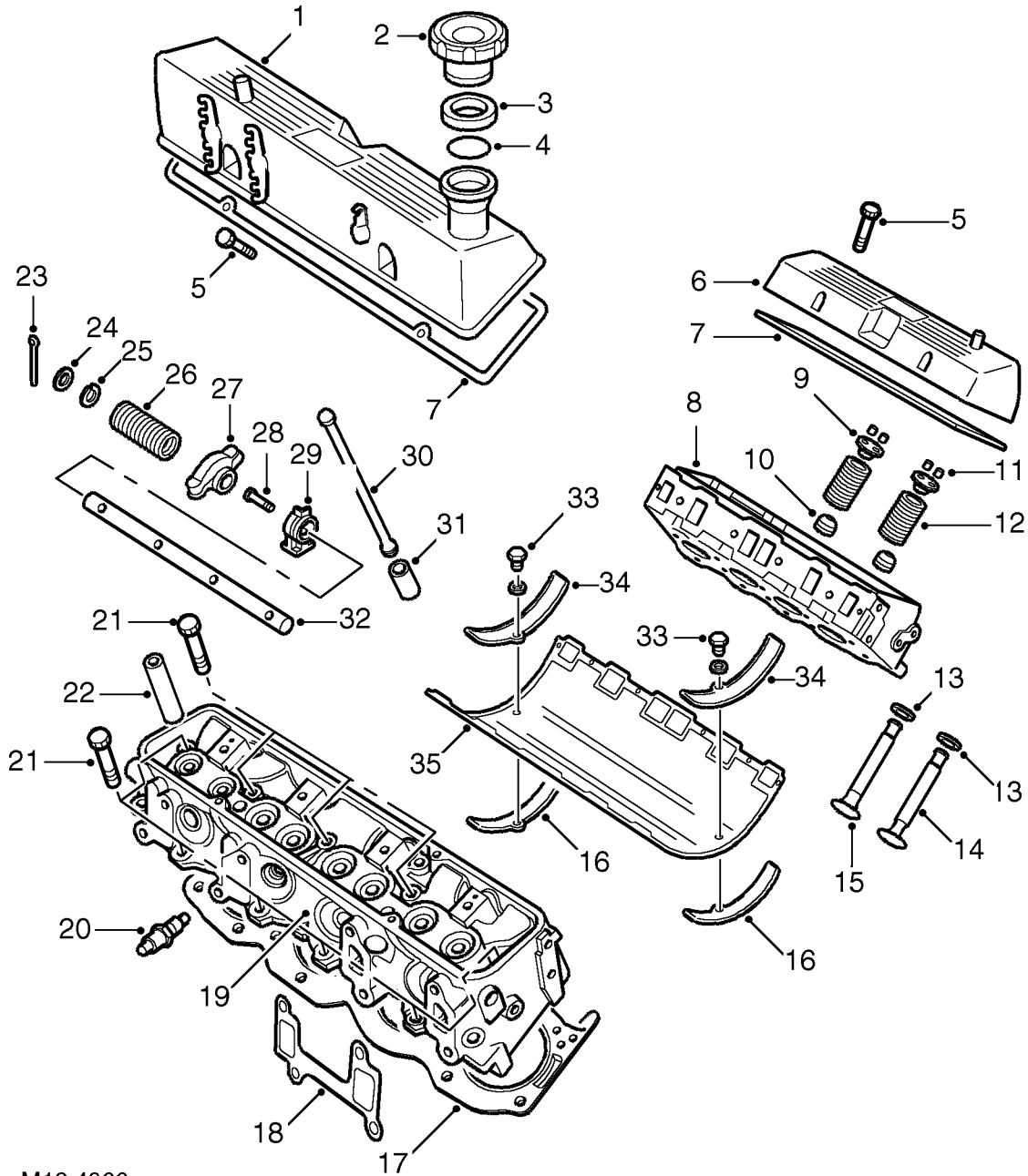

M12 4966



1. Rocker cover - right hand
2. Engine oil filler cap
3. Oil filler dust cap seal
4. 'O' ring - oil filler cap
5. Bolt - rocker cover (4 off; 2 x short, 2 x long)
6. Rocker cover - left hand
7. Gasket - rocker cover
8. Cylinder head - left hand
9. Valve spring cap (16 off)
10. Valve stem oil seals (16 off)
11. Collets (16 pairs)
12. Valve spring (16 off)
13. Valve seat insert (16 off)
14. Exhaust valve (8 off)
15. Inlet valve (8 off)
16. Seal - inlet manifold gasket (2 off)
17. Gasket - cylinder head (2 off)
18. Gasket - exhaust manifold
19. Cylinder head - right hand
20. Spark plug (8 off)
21. Bolt - cylinder head (3 x long & 7 x short per cylinder head)
22. Valve guide (16 off)
23. Split pin (4 off)
24. Washers - plain (4 off)
25. Washers - spring (4 off)
26. Spring - rocker shaft (6 off)
27. Rocker arm
28. Pedestal bolt
29. Pedestal
30. Push rod
31. Hydraulic tappet
32. Rocker shaft
33. Screw/washer - inlet manifold gasket clamp (2 off)
34. Clamp - inlet manifold gasket (2 off)
35. Gasket - inlet manifold

CYLINDER BLOCK COMPONENTS - from 99MY

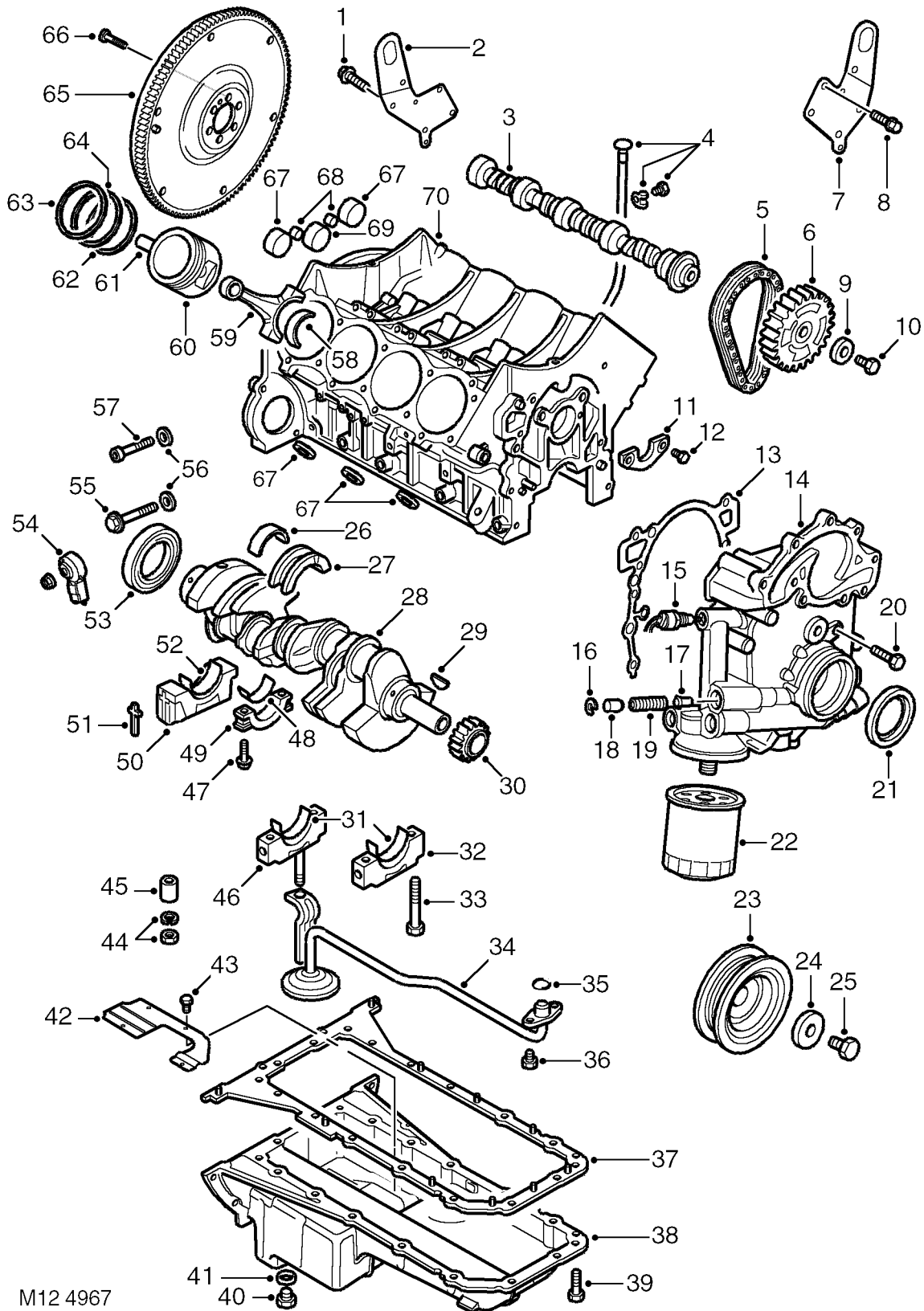

M12 4967



1. Bolt - Rear lifting eye (2 off)
2. Rear lifting eye
3. Camshaft
4. Dipstick, dipstick tube, clamp and bolt
5. Timing chain
6. Camshaft sprocket
7. Front lifting eye
8. Bolt - Front lifting eye (2 off)
9. Washer
10. Bolt - camshaft timing gear
11. Thrust plate - camshaft end-float
12. Bolt - camshaft thrust plate
13. Gasket - front cover
14. Front cover
15. Oil pressure switch
16. Circlip
17. Plunger - oil pressure relief valve
18. Plug - oil pressure relief valve
19. Spring - oil pressure relief valve
20. Bolt
21. Crankshaft front oil seal
22. Oil filter element
23. Crankshaft front pulley
24. Washer
25. Bolt - crankshaft front pulley
26. Upper main bearing seal
27. Upper centre main bearing shell and thrust washer
28. Crankshaft
29. Woodruff key
30. Crankshaft timing gear
31. Lower main bearing shells
32. Numbers 1, 2 and 3 main bearings
33. Bolt - main bearing caps
34. Oil pick-up pipe and strainer
35. 'O' ring
36. Screw - oil pick-up pipe (2 off)
37. Gasket - sump
38. Sump
39. Bolt - sump
40. Oil sump drain plug
41. Sealing washer
42. Baffle plate - oil sump
43. Screws - baffle plate (4 off)
44. Stiffener and nut - oil pick-up pipe to main bearing cap
45. Spacer - oil pick-up pipe to main bearing cap
46. Number 4 main bearing cap
47. Bolt - connecting rod big-end bearing cap
48. Connecting rod big-end bearing shell - lower
49. Connecting rod big-end bearing cap
50. Number 5 - rear main bearing cap
51. Cruciform seal - rear main bearing cap
52. Number 5 - rear main bearing seal
53. Crankshaft rear oil seal
54. Crankshaft knock sensor
55. Side bolt - main bearing cap
56. Dowty washers
57. Side Allen bolt - main bearing cap
58. Connecting rod big-end bearing shell - upper
59. Connecting rod
60. Piston
61. Gudgeon pin
62. Oil control ring
63. Top compression ring
64. 2nd compression ring
65. Flywheel / drive plate and starter ring gear
66. Bolt - flywheel / drive plate
67. Core plugs
68. Tappet oil gallery plugs (2 off)
69. Plug - Camshaft rear bore
70. Cylinder block

DESCRIPTION - up to 99MY

For description and operation of V8 engine before 99MY, refer to 4.0/4.6 V8 Engine Overhaul Manual.

DESCRIPTION - from 99MY

General

The V8 petrol engine is an eight cylinder, water cooled unit having two banks of four cylinders positioned at 90 degrees to each other. The engine comprises five main castings - two cylinder heads, cylinder block, front cover and the oil sump, all of which are manufactured from aluminium alloy. The engine is available in 4.0 litre and 4.6 litre versions and each type can be supplied as high compression or low compression variants, dependent on market requirements.

Cylinder heads

The cylinder heads are fitted with replaceable valve guides and valve seat inserts with the combustion chambers formed in the head. Each cylinder head is sealed to the cylinder block with a multi-layer gasket. The exhaust manifolds are bolted to the outside of each cylinder head whilst the inlet manifolds are located in the centre of the 'Vee' and are bolted to the inside face of each head. Inlet and exhaust manifolds are sealed to the cylinder heads by means of gaskets.

Each cylinder has a single inlet and exhaust valve. The exhaust valves are of the 'carbon break' type, a recess on the valve stem prevents a build-up of carbon in the valve guide by dislodging particles of carbon as the valve stem moves up and down the guide. Inlet and exhaust valve stem oil seals are fitted at the top of each valve guide. Valve operation is by means of rocker arms, push rods and hydraulic tappets. Each of the rocker arms is located on a rocker shaft which is supported by means of pedestals bolted to the cylinder heads. A spring, positioned on either side of each rocker arm, maintains the correct relative position of the arm to its valve stem. The rocker arms are operated directly by the push rods which pass through drillings in the cylinder heads and cylinder block. The bottom end of each push rod locates in a hydraulic tappet operated by the single, chain driven camshaft.

The rocker covers are bolted to the cylinder heads and are sealed to the heads by a rubber gasket. Stub pipes for crankcase ventilation hose connections are fitted to each rocker cover, the pipe in the right hand rocker cover incorporates an oil separator. The engine oil filler cap is situated in the right hand cover.

Cylinder block and camshaft

The cylinder block is fitted with cast iron cylinder liners which are shrink-fitted and locate on stops in the block. The camshaft is positioned in the centre of the cylinder block and runs in one-piece bearing shells which are line bored after fitting. Camshaft end-float is controlled by a thrust plate bolted to the front of the cylinder block. A timing gear, chain driven by the crankshaft timing gear is bolted to the front of the camshaft.

Crankshaft and main bearings

The crankshaft is carried in five main bearings. The upper main bearing shell locations are an integral part of the cylinder block casting. The lower main bearing caps are bolted to the cylinder block on either side of the upper bearing shell locations with an additional bolt being inserted into each cap from either side of the cylinder block. The rear main bearing cap carries the crankshaft rear oil seal and is sealed to the cylinder block by means of cruciform shaped seals in each side of the cap. Number four main bearing cap carries the stud fixing for the oil pick-up pipe. Lower main bearing shells are plain whilst the upper shells have an oil feed hole and are grooved. Crankshaft end-float is controlled by the thrust faces of the upper centre shell. The crankshaft timing gear is located on the front of the crankshaft by means of a Woodruff key which is also used to drive the gear type oil pump. The drive plate incorporates the crankshaft position sensor reluctor ring, and the assembly is dowel located and bolted to the crankshaft.



Front cover

The front cover is bolted to the front of the cylinder block and is sealed to the block with a gasket. The disposable, full-flow oil filter canister is screwed to the front cover, which also carries the oil pressure switch, oil pressure relief valve and crankshaft front oil seal. The gear type oil pump is integral with the front cover which also has an internal oilway to direct oil from the oil cooler to the filter.

Oil sump

The oil sump is bolted to the bottom of the cylinder block and the front cover and is sealed to both components with a one-piece gasket. A removable baffle to prevent oil surge is fitted in the sump. The oil pick-up pipe and strainer assembly is positioned within the sump. The assembly is attached at the pick-up end to a stud screwed into number four main bearing cap and at the delivery end to the oil pump. The oil drain plug is located in the bottom of the sump and is sealed with a washer.

Pistons and connecting rods

Each of the aluminium alloy pistons has two compression rings and an oil control ring. The pistons are secured to the connecting rods by semi-floating gudgeon pins. Each gudgeon pin is offset by 0.5 mm (0.02 in). The top of each piston is recessed, the depth of recess determining the compression ratio of the engine. Plain big-end bearing shells are fitted to each connecting rod and cap.

Lubrication

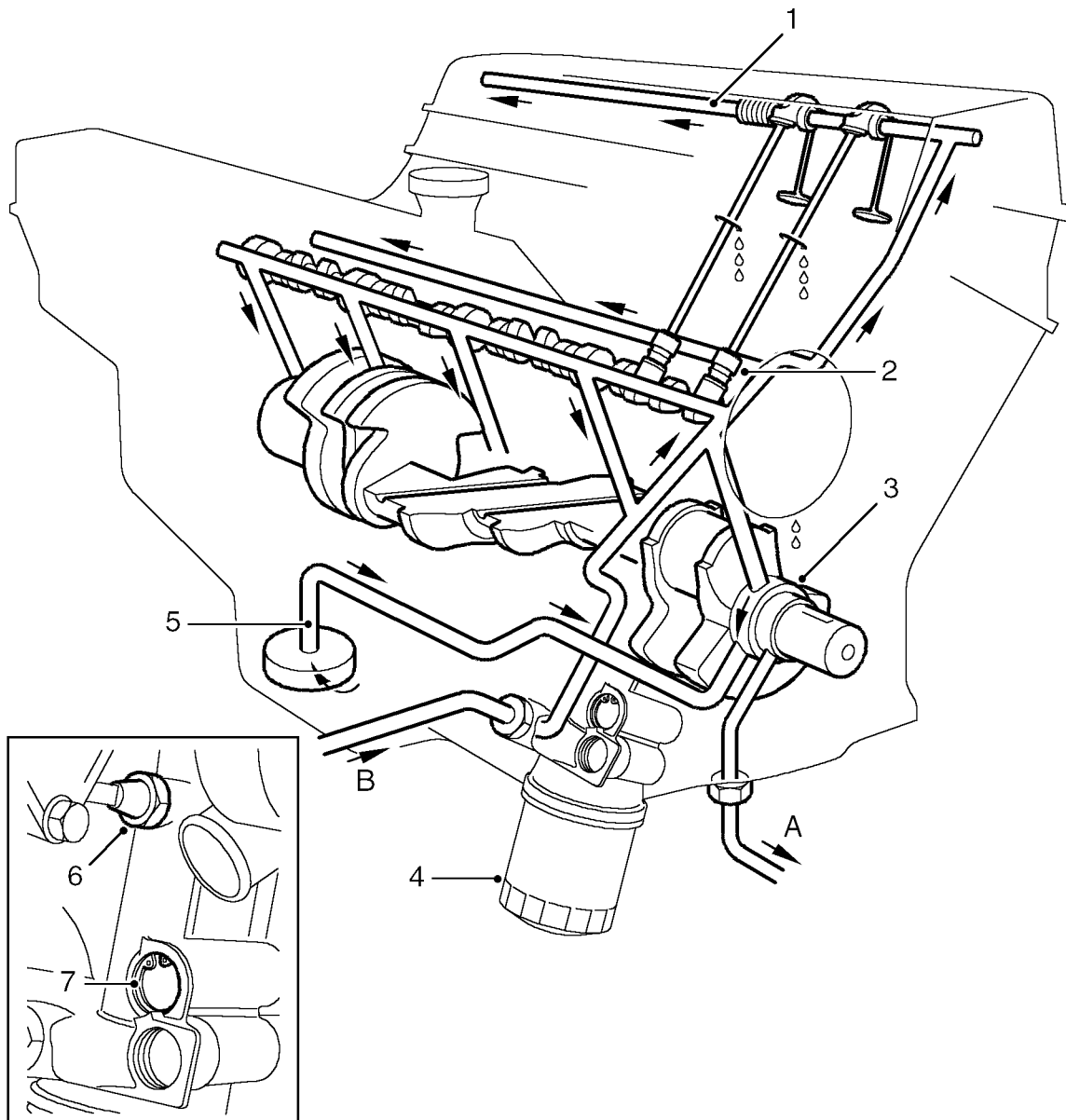

M12 4968

- 1. Rocker shaft assembly
- 2. Hydraulic tappet
- 3. Oil pump
- 4. Oil filter element
- 5. Oil pick-up pipe and strainer
- 6. Oil pressure switch
- 7. Oil pressure relief valve
- A. - to oil cooler
- B. - from oil cooler



Oil is drawn from the sump through a strainer and into the oil pump via the oil pick-up pipe. Pressurised oil from the pump passes through the oil cooler mounted in front of the radiator and returns to the full-flow oil filter element. Oil from the filter passes into the main oil gallery and through internal drillings to the crankshaft where it is directed to each main bearing and to the big-end bearings via numbers 1, 3 and 5 main bearings. Excess oil pressure is relieved by the oil pressure relief valve. An internal drilling in the cylinder block directs oil to the camshaft where it passes through further internal drillings to the hydraulic tappets, camshaft bearing journals and rocker shafts. Lubrication to the pistons, small ends and cylinder bores is by oil grooves machined in the connecting rods and by splash.

Oil pressure switch

The oil pressure warning light switch registers low oil pressure in the main oil gallery on the outflow side of the filter. Whilst the engine is running and oil pressure is correct, the switch is open. When the ignition is switched on or if oil pressure drops below the pressure setting of the switch, the switch closes and the low oil pressure warning lamp located in the instrument pack will illuminate.

Hydraulic tappets

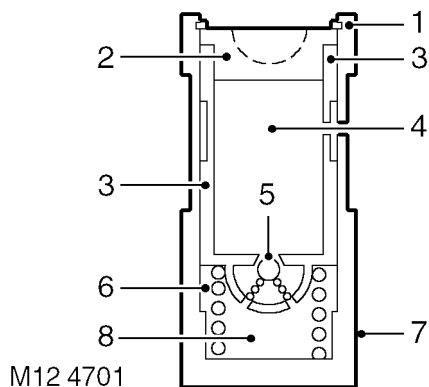

- 1. Clip
- 2. Pushrod seat
- 3. Inner sleeve
- 4. Upper chamber
- 5. Non-return ball valve
- 6. Spring
- 7. Outer sleeve
- 8. Lower chamber

The hydraulic tappet provides maintenance free, quiet operation of the valves. This is achieved by utilizing engine oil pressure to eliminate the clearance between the rocker arms and valve stems. When the valve is closed, engine oil pressure present in the upper chamber, passes through the non-return ball valve and into the lower chamber. When the cam begins to lift the outer sleeve, the resistance of the valve spring, felt through the push rod and seat, causes the tappet inner sleeve to move downwards inside the outer sleeve. This downwards movement closes the non-return ball valve and increases the pressure in the lower chamber sufficiently to ensure that the valve is fully opened by the push rod. As the tappet moves off the peak of the cam, the non-return ball valve opens thereby allowing the pressure in both chambers to equalize. This ensures that the valve will be fully closed when the tappet is on the back of the cam.

Crankcase ventilation

A positive crankcase ventilation system is used to vent crankcase gases to the air induction system. Gases are drawn from the left hand rocker cover to a tapping in the throttle body. An oil separator is incorporated in the hose connection stub pipe in the right hand rocker cover, gases from this connection are drawn to a tapping in the inlet manifold.

