



Land Rover  
Range Rover

## Workshop Bulletin

ATTENTION SERVICE MANAGER

DECEMBER 1987

BULLETIN No. SLR 621 EN WB 3

**LAND ROVER**

**LT85 LIGHTWEIGHT  
DIVIDED-CASE GEARBOX**

---

Further supplies of this Bulletin can be obtained, free of charge, from:

Land Rover Merchandising Service,  
P.O. Box 534, Erdington, Birmingham B24 0QS

SERVICE

Land Rover Service Division

**INTRODUCTION**

This Workshop Bulletin is a supplement to the current Land Rover Workshop Manual Publication SLR 621 EN **WM** and covers the introduction and overhaul of the LT 85 light weight divided case gearbox. This unit replaces the earlier heavy duty LT 85 gearbox fitted to the basic V8 engined Land Rover 90 and 110 models. The heavy duty version is still being used for certain non-standard applications.

The new gearbox, which is interchangeable with the heavy duty version, can be recognised by the prefix 22C before the serial number. The gearbox was first fitted from the following vehicle numbers:

Land Rover 90 V8. VIN SALLD VBV 7AA 299109.  
Gearbox number 22C 00070.

Land Rover 110 V8. VIN SALLD HAV 8BA 298614.  
Gearbox number 22C 00061.

The individual gears and shafts are not, however, interchangeable between the two gearboxes.

**GEARBOX DATA**

Ratios: as heavy duty version.

Lubrication: as heavy duty version.

Torque figures: as heavy duty gearbox where applicable with the exception of the following:

Divided case retaining bolts M8- 7off (5 bolts and two bolts and nuts) 22- 28 Nm (16-21 lbs.ft.)

Maintenance: Oil check and top-up and drain and renew oil are at the same mileage intervals but the drain and refill method differs from the heavy duty gearbox, as follows:

1. Immediately after a run, when the oil is warm, park the vehicle on level ground and disconnect the battery. Drain-off the oil into a container by removing the drain plug anti-clockwise from beneath the gearbox casing using a 12,7mm (1/2in) square socket drive. When all the oil is drained, clean and refit the drain plug and tighten to the correct torque.

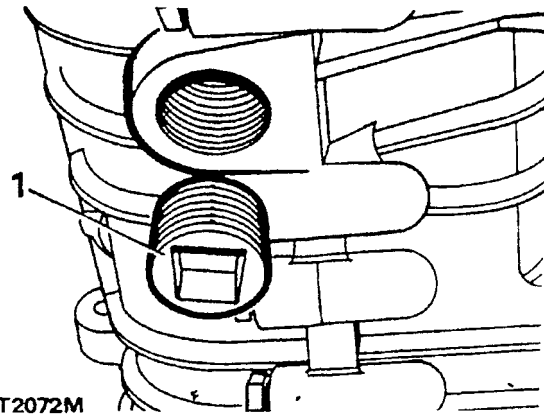

ST2072M

2. Remove the square headed oil level/filler plug from the left-hand side of the gearbox and inject oil of the correct grade until the oil is level with the filler hole. Clean and fit the level/filler plug and tighten to the correct torque. Wipe away any surplus oil and reconnect the battery.

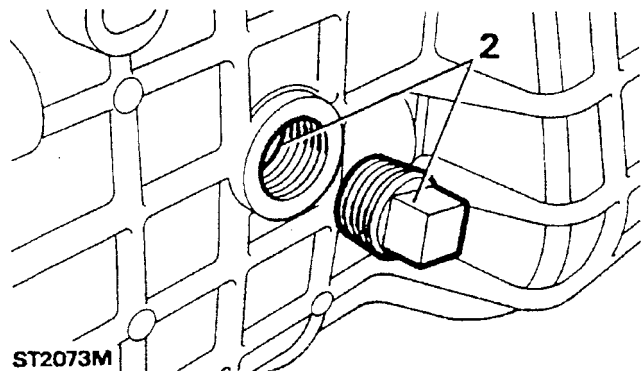

ST2073M

**GEARBOX AND TRANSFER BOX REMOVAL**

This operation is the same as that described in Supplement LSM 25WS and the current Land Rover Workshop Manual Publication SLR 621 EN WM for the heavy duty LT 85 gearbox.

In the interests of safety, it is essential that the locally manufactured cradle is used with the hydraulic ramp. Before fitting the cradle the gearbox filler/level plug must be removed and a suitable blank fitted.

**OVERHAUL LT85 LIGHT WEIGHT DIVIDED CASE GEARBOX.**

**Service Tools**

- 18C 284      Impulse extractor.
- LST 284-1    Reverse idler shaft remover adaptor.
- LST 101      Gauge first gear end-float.
- LST 102      Mainshaft oil seal remover, replacer.
- MS 47        Hand press.

With the exception of MS 47 the above are existing tools used on the heavy duty IT 85 integral case gearbox.

**Special sockets and spanners.**

- 41mm socket -      Layshaft fifth gear retaining nut.
- 5mm Allan key -    Reverse shaft retaining plate

**Locally manufactured tools.**

In addition to the above service tools, the following tools can be locally manufactured to assist the dismantling and assembly of the gearbox. These tools are the same as for the heavy duty gearbox except the stand to which a small modification is necessary.

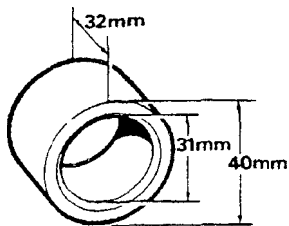

ST1476M

Spacer for retaining layshaft rear bearing.

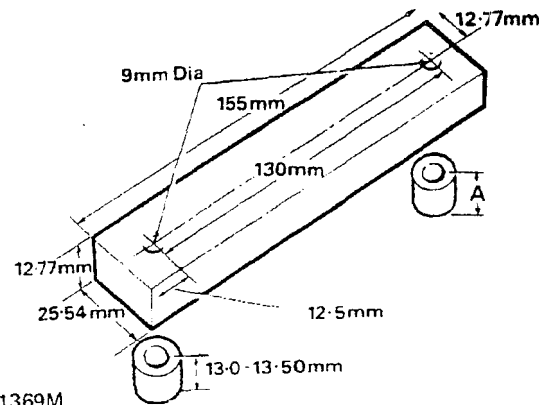

ST1369M

Selector detent spring retaining tool and spacers.

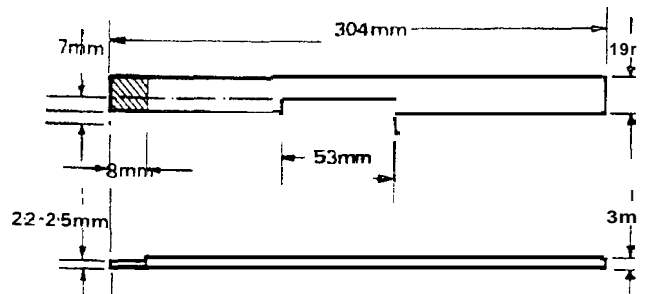

ST1371M

Gauge for reverse cross-over lever adjustment.

**Continued**

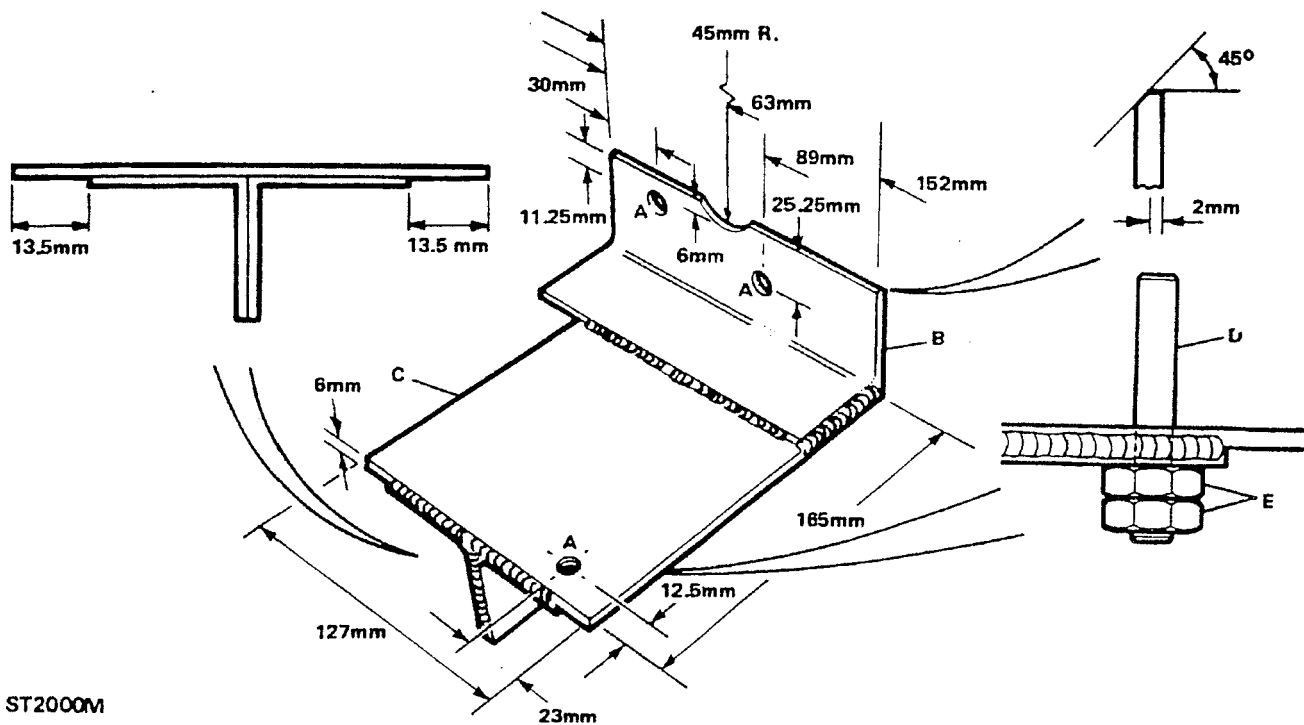

ST2000M

**Stand for securing the gearbox in a vice**

- A. 11mm diameter holes.
- B. Make from 50mm x 6mm steel angle.
- C. Make from 6mm steel plate.
- D. 10mm diameter stud 70mm long with 25mm of thread for adjustment.
- E. 10mm nuts.

Note: Item D is where the modification to the original stand is necessary.

**Material and welding specification**

Steel plate BS 1449 Grade 4 or 14  
Arc welding BS 5135.

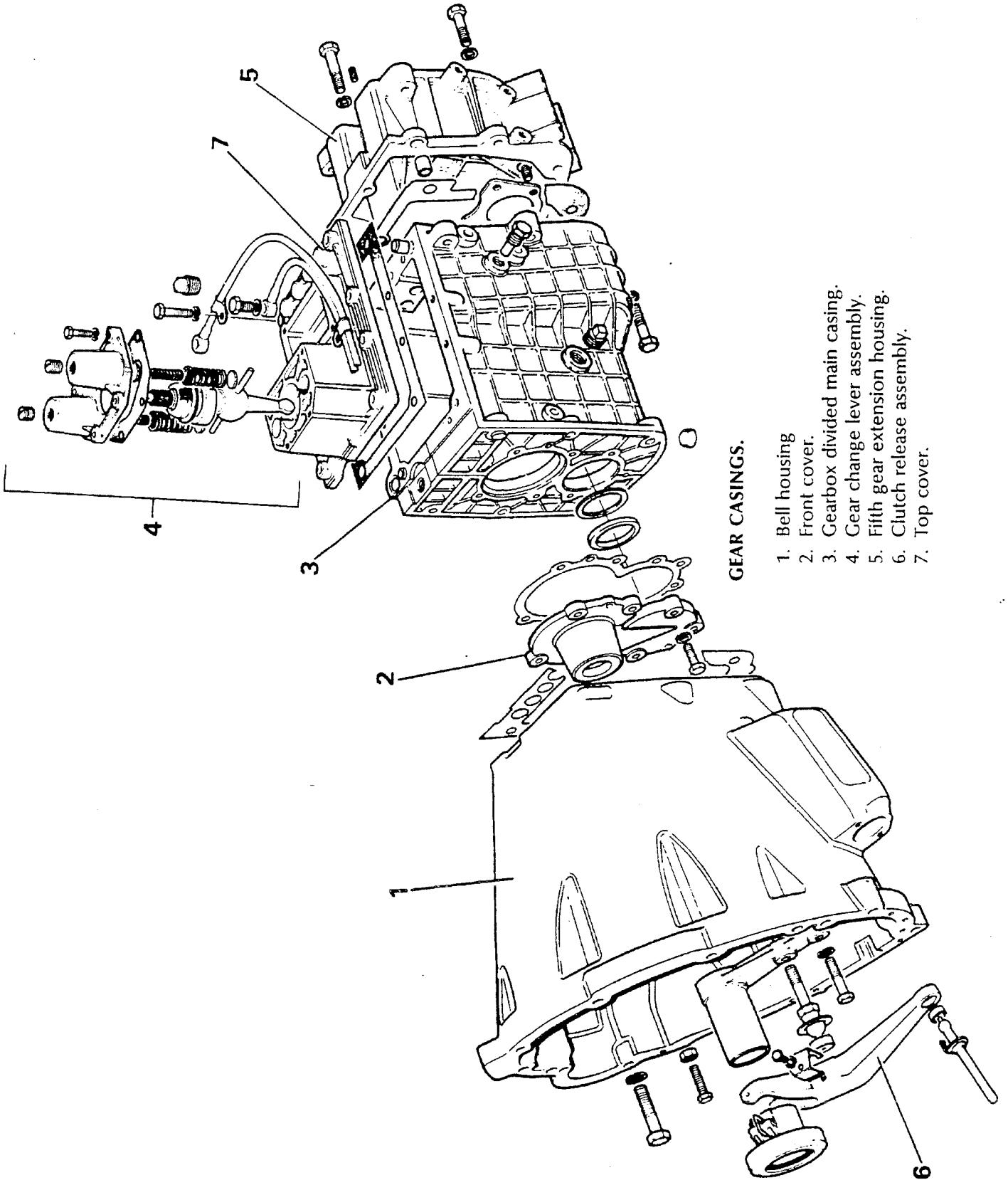

**GEAR CASINGS.**

- 1. Bell housing
- 2. Front cover.
- 3. Gearbox divided main casing.
- 4. Gear change lever assembly.
- 5. Fifth gear extension housing.
- 6. Clutch release assembly.
- 7. Top cover.

GEARS AND SHAFTS

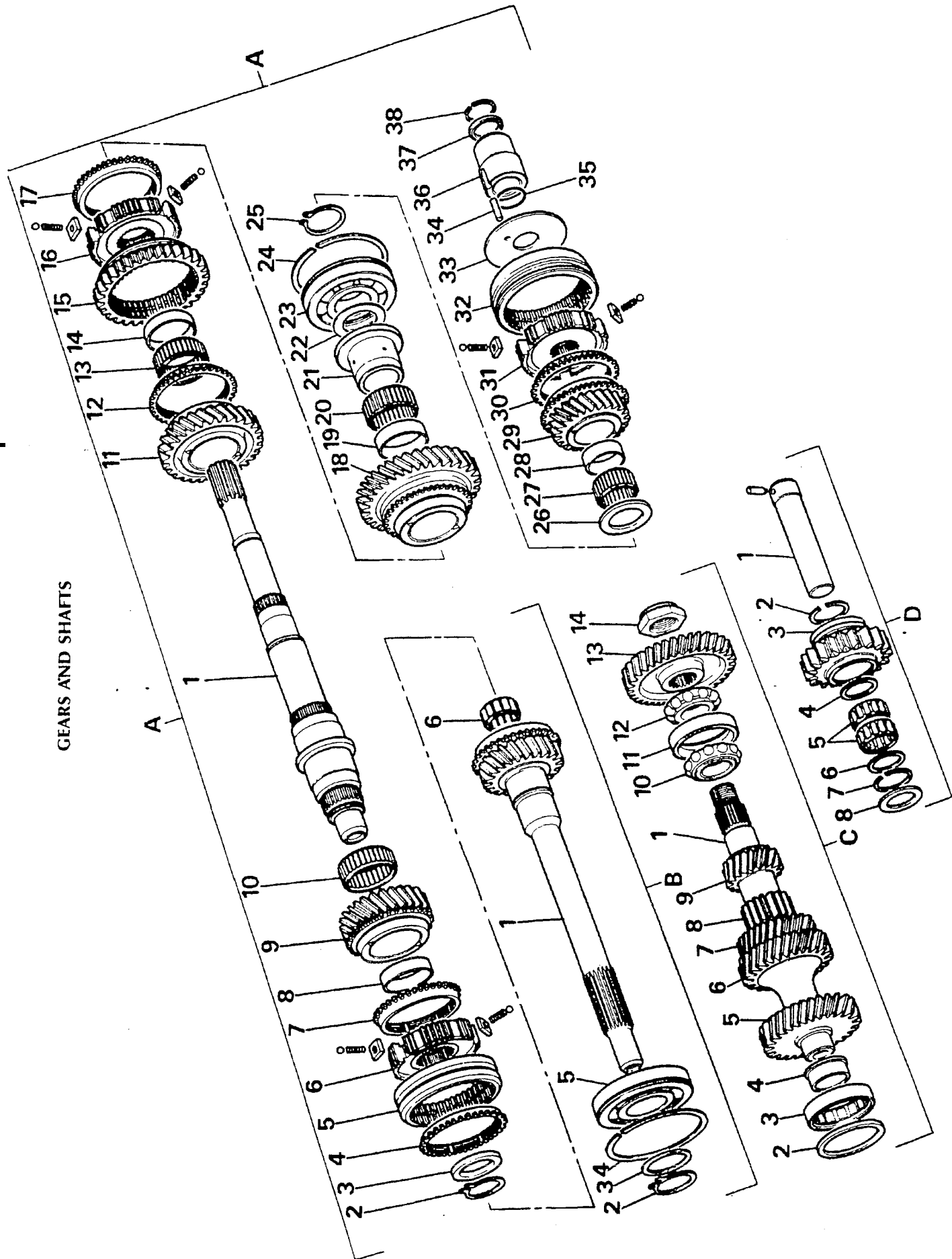

## KEY TO GEARS AND SHAFTS

### MAINSHAFT ASSEMBLY A.

1. Mainshaft.
2. Circlip.
3. Selective washer.
4. 4th gear baulk ring.
5. 3rd/4th gear synchromesh sleeve.
6. 3rd/4th gear synchromesh hub.
7. 3rd gear baulk ring.
8. Spacer.
9. 3rd gear.
10. Needle roller bearing.
11. 2nd gear.
12. 2nd gear baulk ring.
13. Needle roller bearing.
14. Spacer.
15. 1st/2nd synchromesh sleeve and reverse gear.
16. 1st/2nd gear synchromesh hub.
17. 1st gear baulk ring.
18. 1st gear.
19. Spacer.
20. Needle roller bearing.
21. 1st gear bush.
22. Selective washer.
23. Ball bearing.
24. Snap ring.
25. Circlip.
26. Washer.
27. Needle roller bearing.
28. Spacer.
29. 5th gear.
30. 5th gear baulk ring.
31. 5th gear synchromesh.
32. 5th gear synchromesh sleeve.
33. 5th gear Synchromesh plate.
34. Dowel retaining plate.
35. "O" ring seal.
36. Sleeve
37. Selective
38. Circlip.

### INPUT SHAFT ASSEMBLY B.

1. Input shaft and 4th gear
2. Circlip.
3. Selective washer
4. Snap ring.
5. Ball bearing.
6. Needle roller bearing.

### LAYSHAFT ASSEMBLY C.

1. Layshaft
2. Spacer.
3. Roller bearing.
4. Roller bearing track.
5. 4th gear.
6. 3rd gear.
7. 2nd gear.
8. Reverse gear.
9. 1st gear.
10. Inner ball bearing race.
11. Bearing track.
12. Outer ball bearing race.
13. 5th gear.
14. 5th gear retaining nut.

### REVERSE SHAFT ASSEMBLY D

1. Reverse idler gear shaft
2. Wire circlip.
3. Reverse idler gear.
4. Washer.
5. Needle roller bearing.
6. Washer.
7. Wire circlip.
8. Thrust washer.

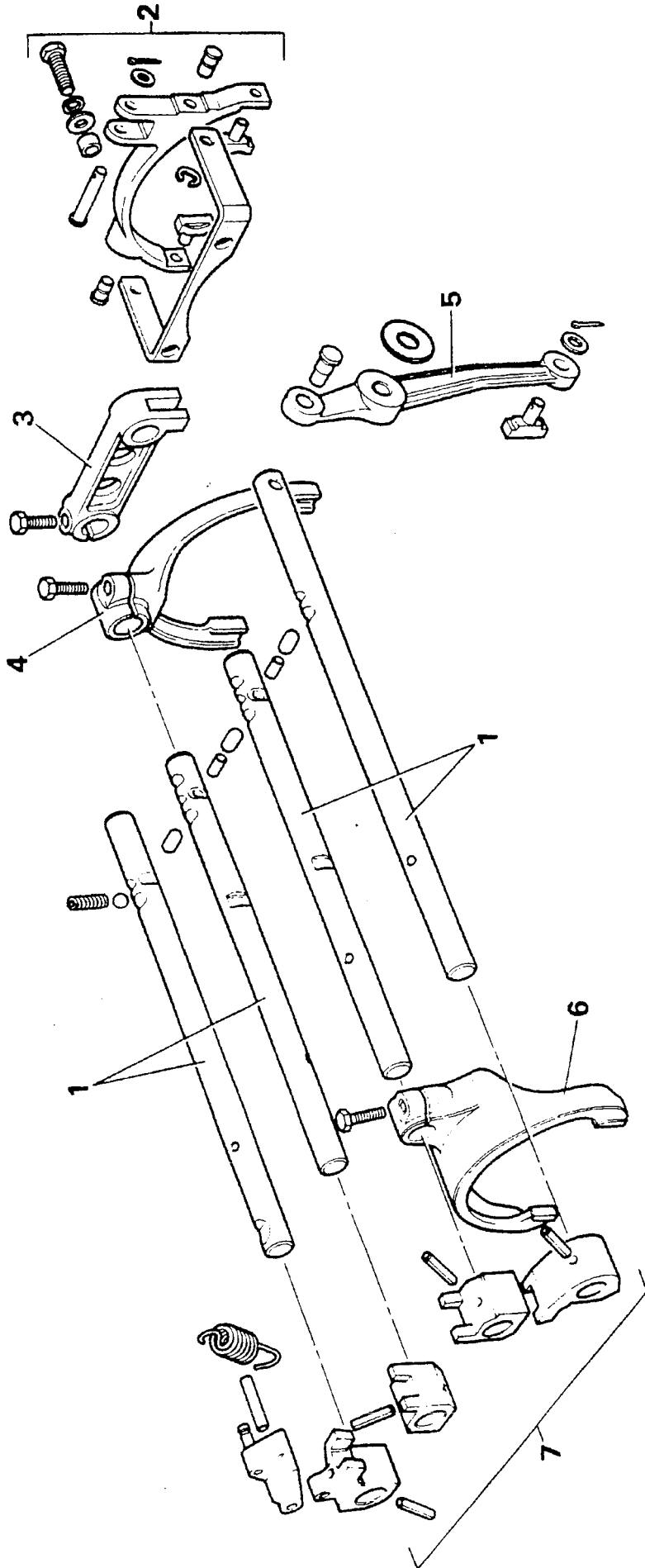

**GEAR SELECTORS.**

1. Selector rails.
2. Fifth gear selector fork assembly.
3. Reverse gear cross-over lever.
4. First and second gear selector fork.
5. Reverse gear lever.
6. Third and fourth gear selector fork.
7. Selector jaws.



**DISMANTLE**

1. Ensure that the gearbox oil has been drained.
2. Position gearbox on a bench and support with a suitable block of timber.
3. Remove the four bolts and detach the L.H. mounting bracket.
4. Remove the eight bolts, four forward facing and four rearward facing and withdraw the extension housing and gasket.

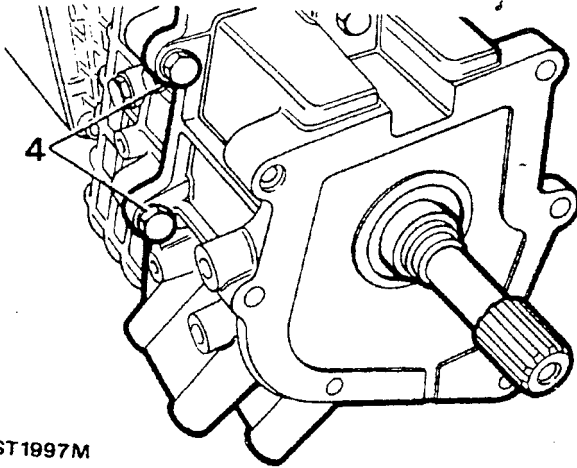

ST1997M

5. Fit the locally manufactured stand to the gearbox and secure with two bolts, nuts, spring and plain washers.
6. Adjust the stud under the gearbox case as necessary so that it just contacts the case to provide support.

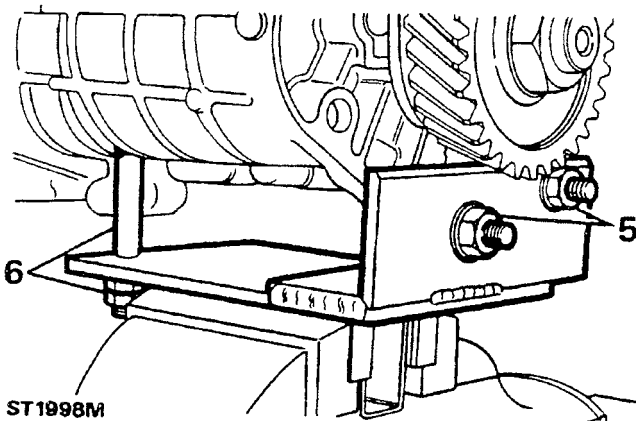

ST1998M

7. Secure the gearbox and stand in a vice.

8. Remove the six bolts and withdraw the bell housing complete with clutch release lever, sleeve and thrust bearing from the gearbox.
9. Remove the bell housing gasket.

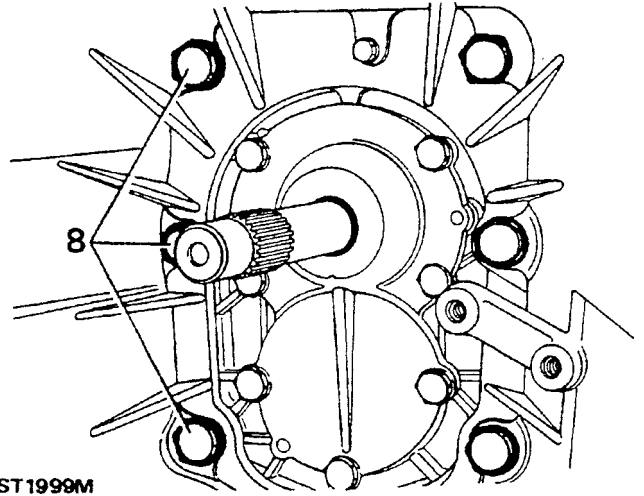

ST1999M

**Bias spring housing and gear lever.**

1. Remove the four bolts and lift the bias spring housing from gearbox.
2. Remove the bias springs and shims. Take care not to allow the lower shims to slip under the gear lever pivot bar into the gearbox.
3. Remove the bias spring housing gasket.
4. Remove the gear lever complete with gaiter and nylon cup.

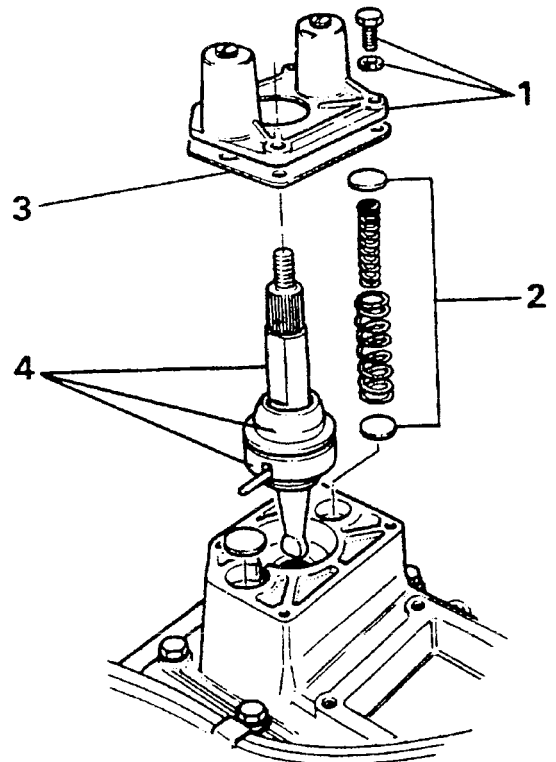

ST2074M

## Gearbox top cover.

1. Remove the reverse light switch, if fitted.
2. Remove breather pipe banjo union fixing bolt.
3. Remove the eight bolts and lift the top cover and breather pipes from gearbox whilst taking care not to allow the detent springs to fall into the gearbox.
4. Remove the detent springs.
5. Remove the top cover gasket.

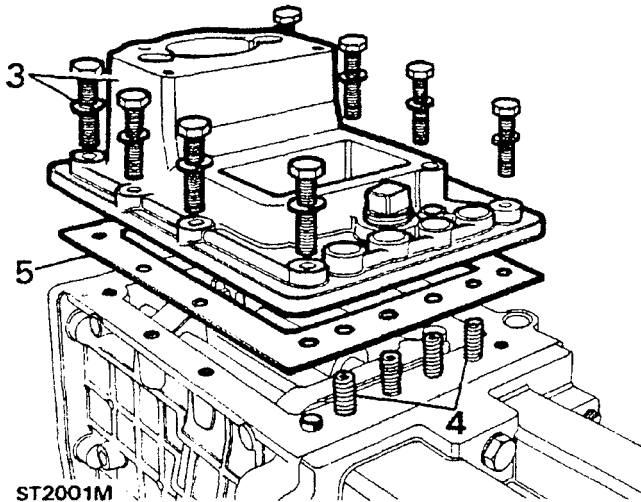

8. Remove the clamp bolt from the third/fourth selector fork and move the selector rail forward.
9. Tap-down the third/fourth jaw roll pin until jaw is free on the selector rail.
10. Withdraw the third/fourth selector rail and jaw.
11. Remove the interlock from the third/fourth selector rail.
12. Tap-down the first/second jaw roll pin until the jaw is free on the selector rail.
13. Remove the clamp bolt from the first/second selector fork and withdraw the first/second selector rail and jaw.
14. Remove the interlock from the first/second selector rail.
15. Lift the reverse cross-over lever from the gearbox.
16. Remove the first/second and third/fourth selector forks.

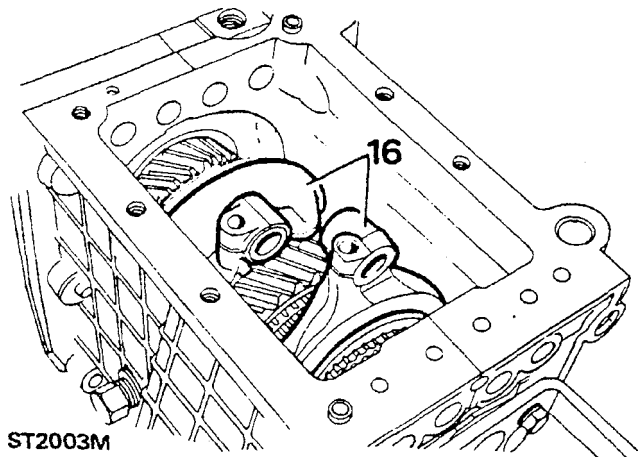

## Selector rails and forks.

1. Using a magnet, withdraw the selector rail detent balls from drillings in gearbox. If the balls are tight leave until the selector rails have been removed.
2. Release reverse gate spring from the knock-over lever and remove from reverse gear rail.
3. Raise the knock-over lever and tap down the reverse jaw roll pin until the jaw is free on the rail.
4. Remove the clamp bolt from the reverse gear cross-over lever, slide the reverse selector rail out from the gearbox and remove the jaw.
5. Remove the split pin, washer, and clevis pin securing the fifth-gear selector fork to the fifth gear rail.
6. Push the selector rail forwards and tap down the fifth-gear jaw roll pin until the jaw is free on the rail.
7. Withdraw the fifth-gear selector rail and jaw from the gearbox.

17. Remove the interlock plungers, and the detent balls, if the latter were not removed in instruction 1.

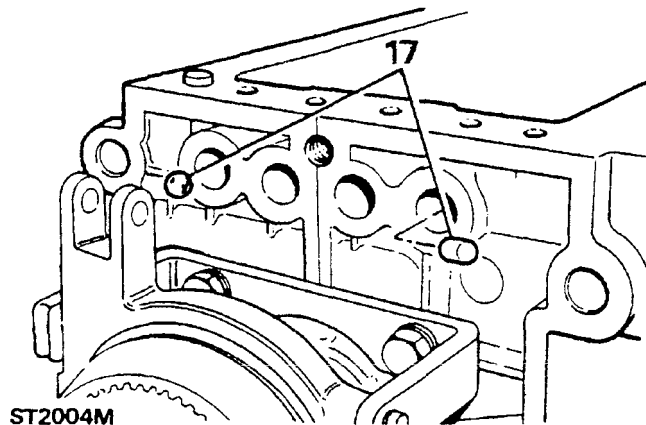

SELECTOR RAILS AND FORKS

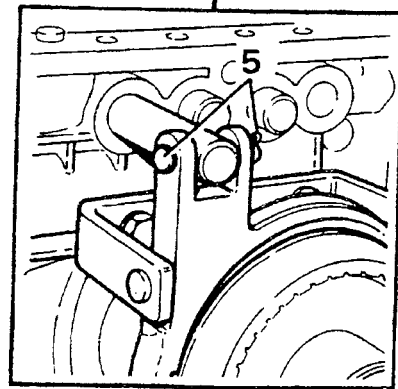
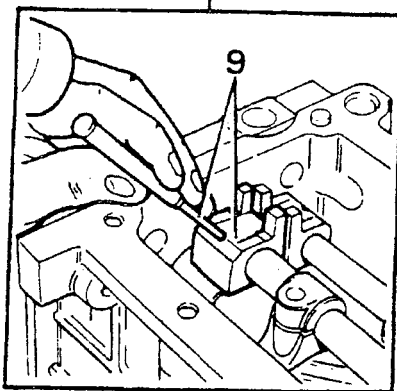
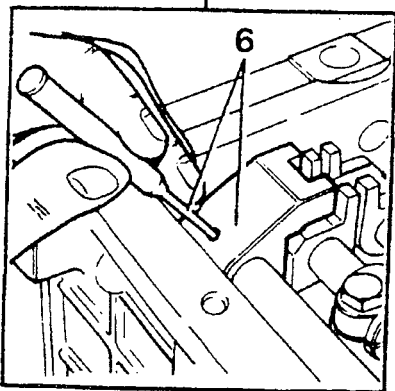
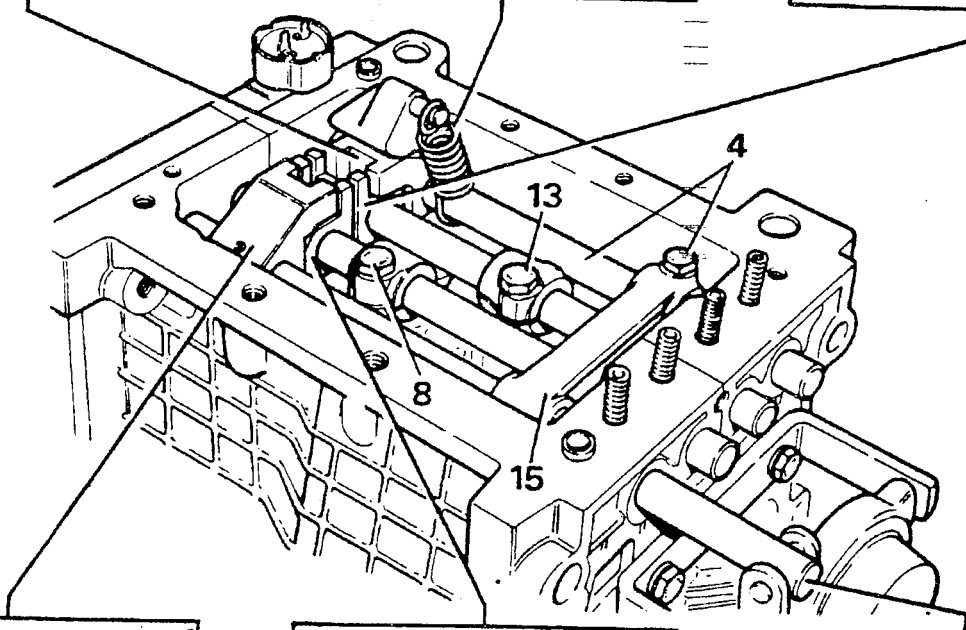
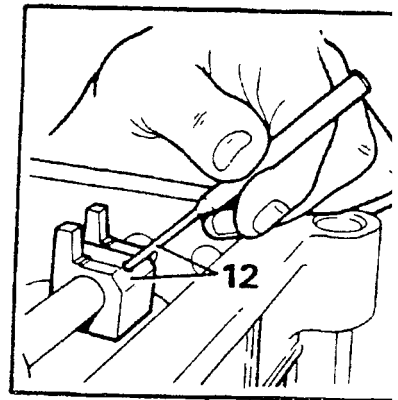
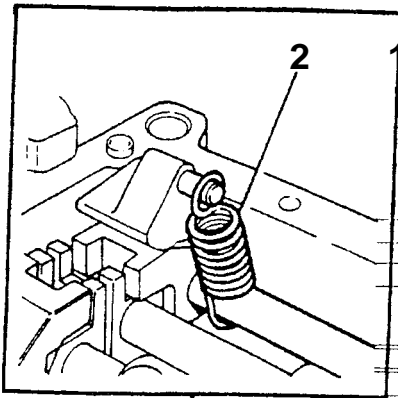
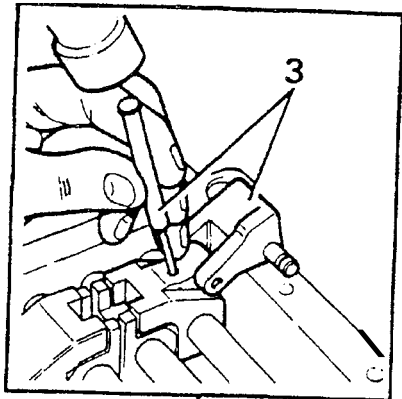

ST2002M

18. Remove the two bolts securing the fifth gear fork and bracket assembly to the gearbox. Do not displace the selector fork slipper pads when removing the fork.

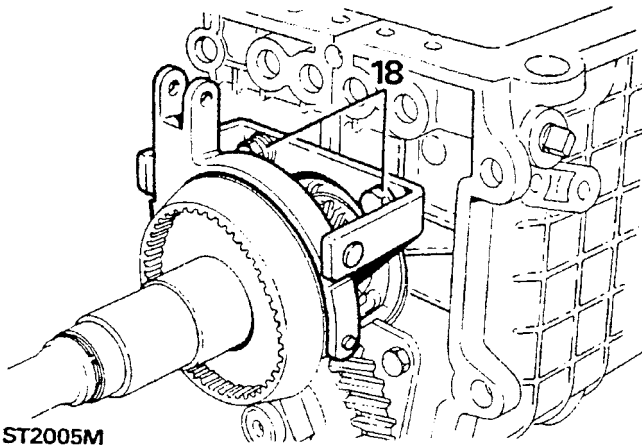

3. Remove the fifth gear, spacer, needle roller bearing and thrust washer.

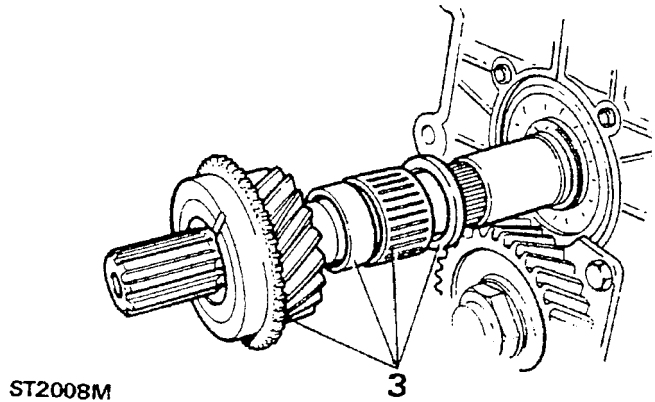

4. Engage both first and fourth gears to lock the gearbox. Release the stake nut collar from the recess in the layshaft and remove the nut and fifth gear.

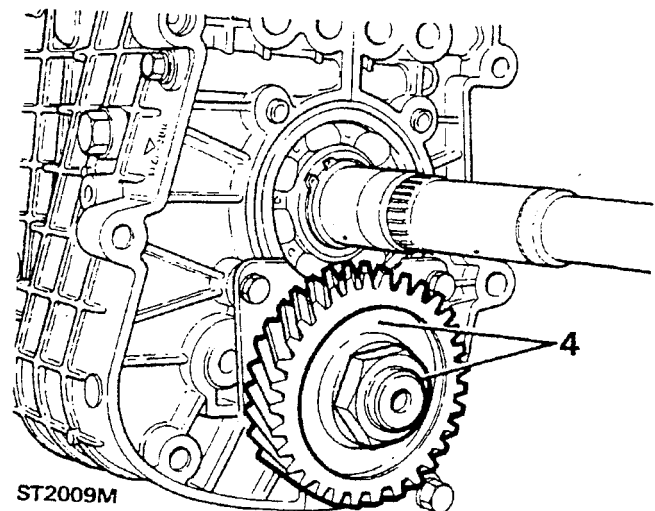

### Reverse shaft, mainshaft, and layshaft.

1. Remove the circlip, selective washer, oil seal collar, and "O" ring from the mainshaft.

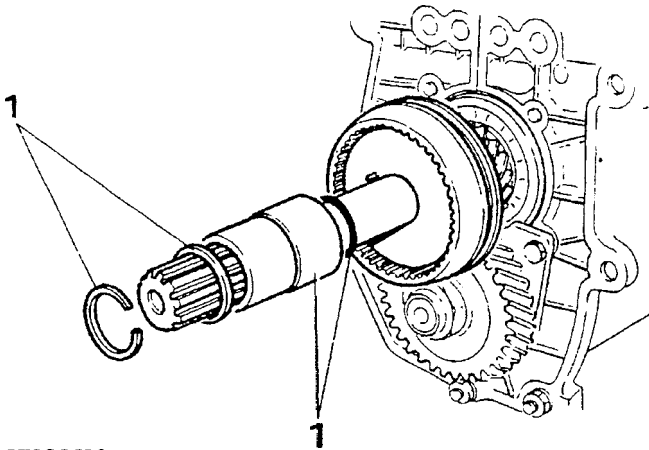

2. Remove the fifth gear synchromesh hub and baulk ring.

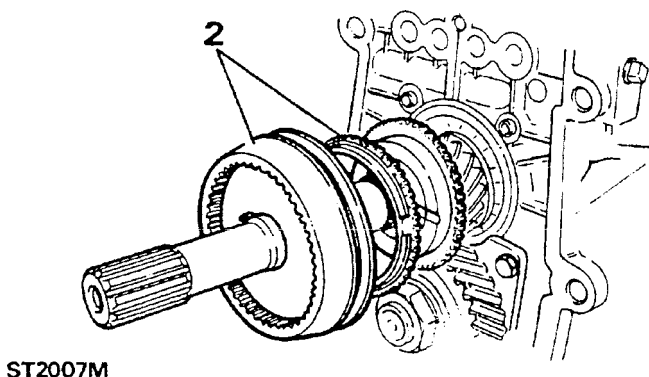

5. Fit the manufactured spacer to the layshaft to keep the rear bearing in position and retain with the stake nut, finger-tight only. Disengage the first and fourth gears.

6. Remove the two socket-headed set screws and two bolts and remove the plate that retains the layshaft bearing track and reverse shaft.

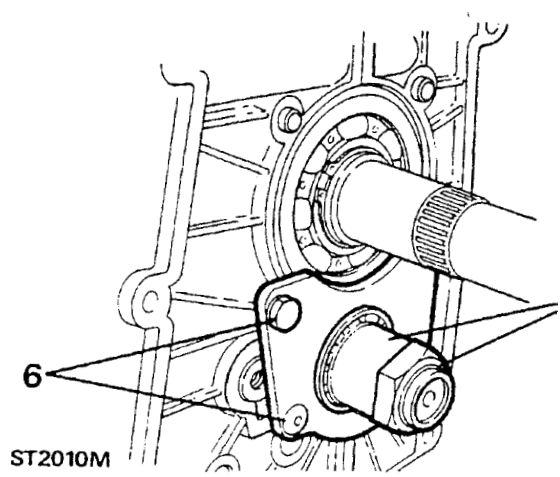

- 7. Remove the seven bolts and withdraw the front cover and gasket.
- 8. Remove the layshaft front bearing spacer and shims.

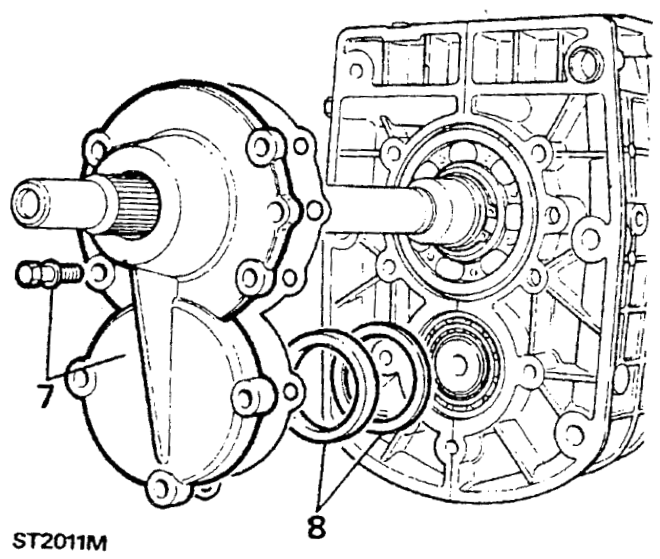

- 9. Remove the gearbox case and stand from the vice.
- 10. Remove the stand from the case.
- 11. Remove the seven bolts that secure the two halves of the case together.
- 12. Rest the case on the bench with the reverse gear idler side downwards.
- 13. Carefully separate the case by tapping with a hide mallet alternately at the four corners, to break the seal.

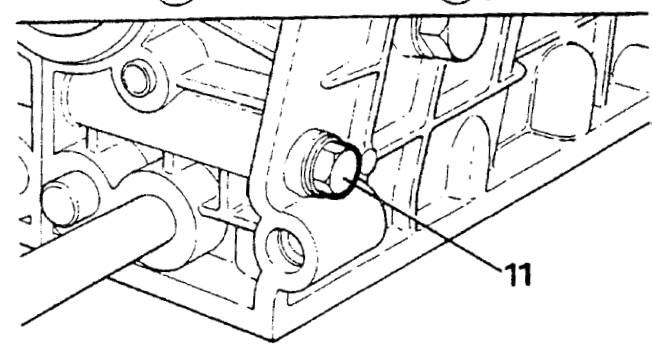
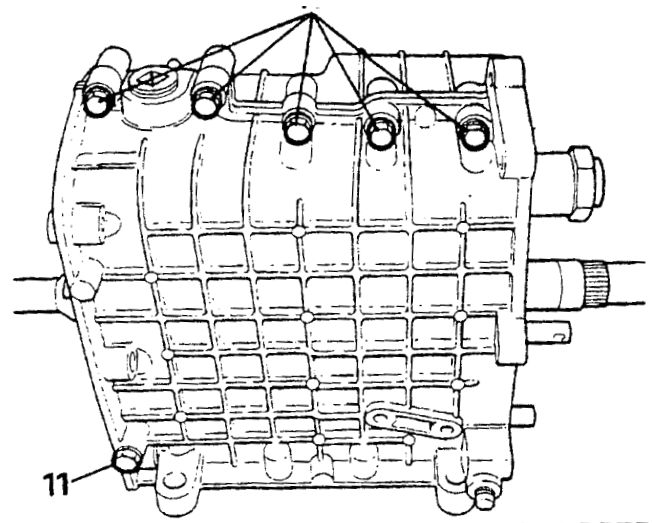

- 14. Lift-out the layshaft assembly.
- 15. Remove the mainshaft assembly.

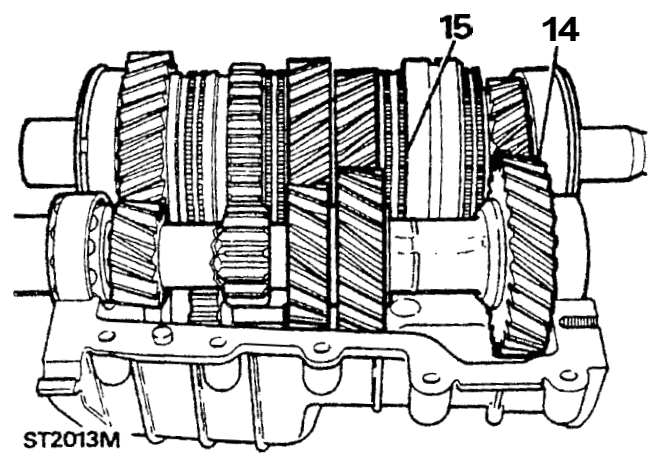

Continued

16. Remove the reverse lever pivot bolt from the outside of the casing.
17. Remove the reverse lever and spacer from the idler gear and case.

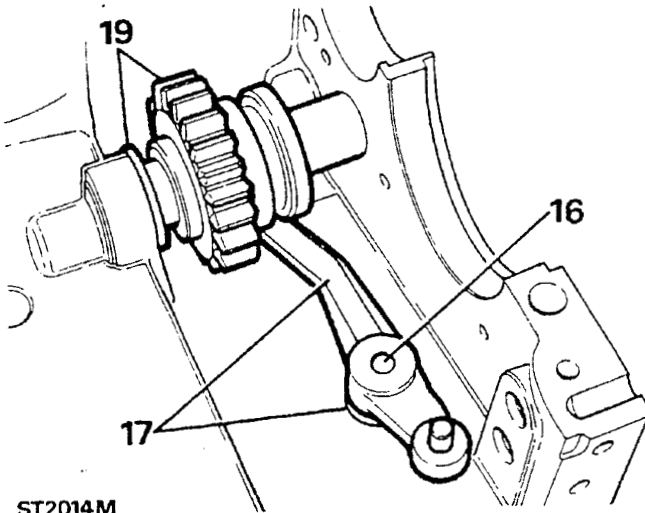

ST2014M

18. To remove the reverse gear idler shaft, place the case on a block of timber and with assistance, hold the case firmly and drive-out the shaft using impulse extractor 18G 284 and adaptor LST 284-1.
19. Remove the reverse idler gear and thrust washer.

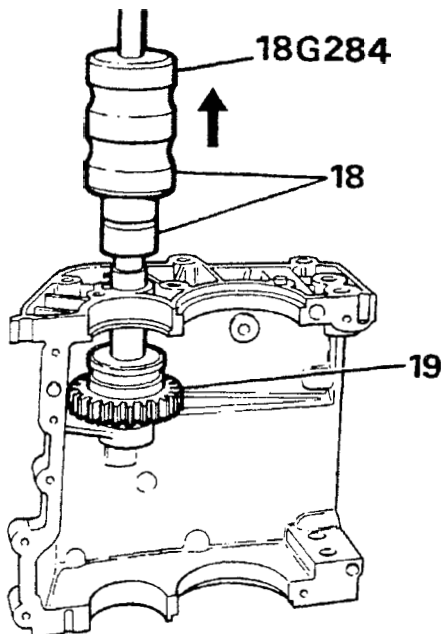

ST2015M

## INSPECTION AND OVERHAUL.

### Main gearbox case

**Note:** The following instructions 1 to 4 are only necessary if the gear casings, plugs or dowels are being renewed.

1. Remove the drain plug.
2. Remove the filler/level plug.
3. Remove the interlock cross drilling plug
4. Remove the six hollow dowels.

### Front cover.

1. Place the front cover on a block of timber and drift-out the oil seal.

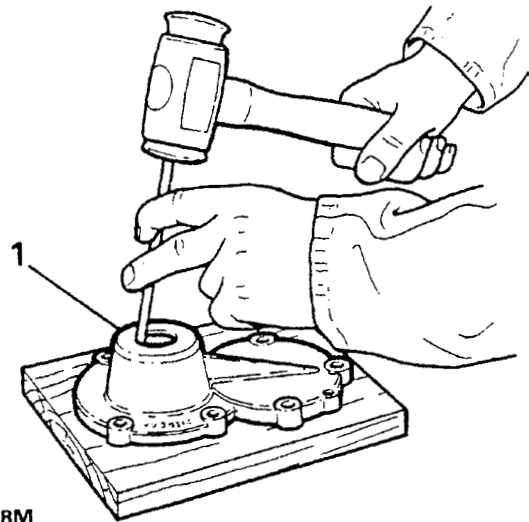

ST2018M

2. Clean the cover and check for damage or burrs.
3. Lubricate the outer diameter of a new seal and using a suitable tube, drift-in the seal, lip side trailing, squarely into the cover.

Continued

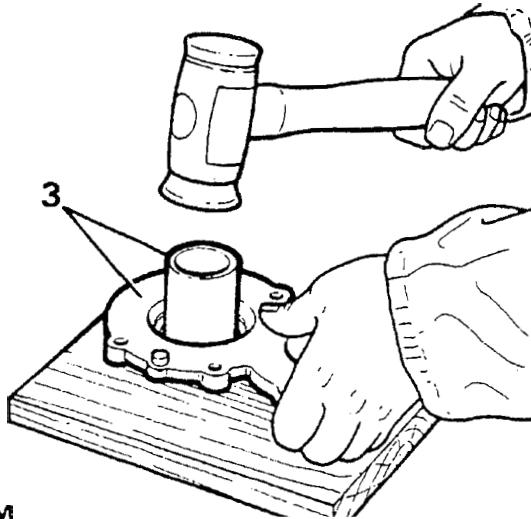

ST2019M

**Gearbox fifth gear extension housing.**

1. Remove the rear oil seal from the extension housing using a suitable drift.
2. If necessary, renew the extension housing dowels.
3. Clean the the exterior and interior and the mating faces.
4. Using service tool LST 102 fit a new seal to the extension housing.

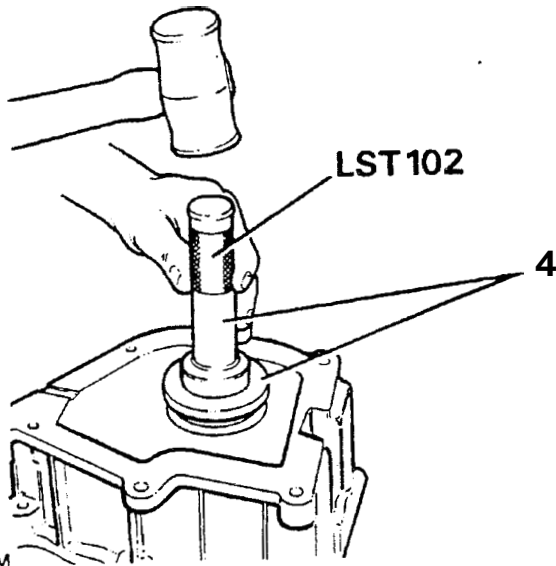

ST1349M

**Bias spring housing and lower gear lever**

1. Secure the housing in a vice and remove the bias spring adjusting screws.
2. Clean the lower gear lever and nylon cup. Check for wear and damage.
3. Check the rubber dust cover for damage.
4. Clean the housing, adjusting screws and bias spring bores.
5. Clean and examine the bias springs.
6. Refit the bias spring screws, two turns only at this stage.

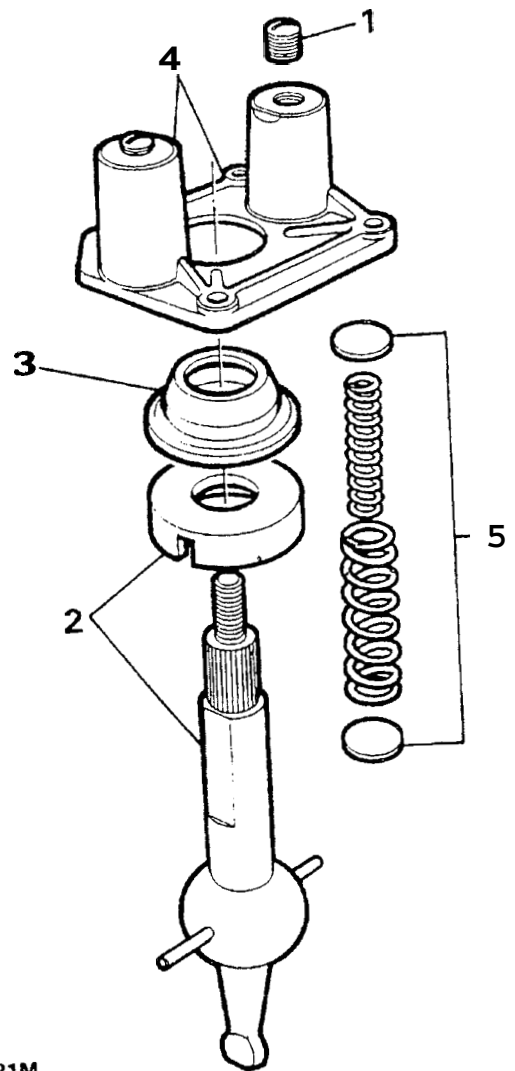

ST2021M

**Top cover**

1. Clean top cover gasket faces and the interior and exterior surfaces.
2. Remove the top filler plug, clean, apply sealant and refit.
3. Clean the gear lever housing and check for cracks and wear.

## Bell housing.

1. Remove the clip retaining the thrust bearing carrier to the clutch operating lever fork if still in position.

**Note: the clip is fitted during assembly to prevent the bearing sliding forward when the gearbox is being fitted to the engine and it may become dislodged in service without detriment.**

2. Withdraw the thrust bearing and carrier assembly from the sleeve.
3. Remove the bolt and spring washer securing the operating lever pivot clip to the lever.
4. Remove the operating lever and pivot slotted washer.
5. Remove the operating lever pivot.
6. Unscrew the single-bolt and remove the bearing sleeve from the bell housing.

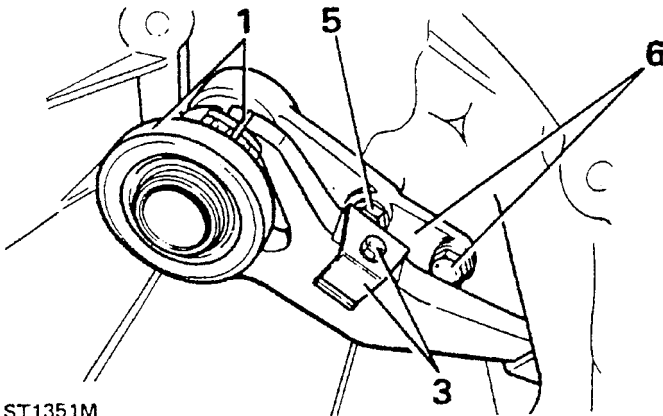

ST1351M

7. If necessary, remove the bearing sleeve dowels.
8. Clean the bell housing exterior and interior and mating faces.
9. **Apply** grease to the lever pivot and inner diameter of bearing carrier.
10. Reassemble the bell housing in the reverse order of dismantling.

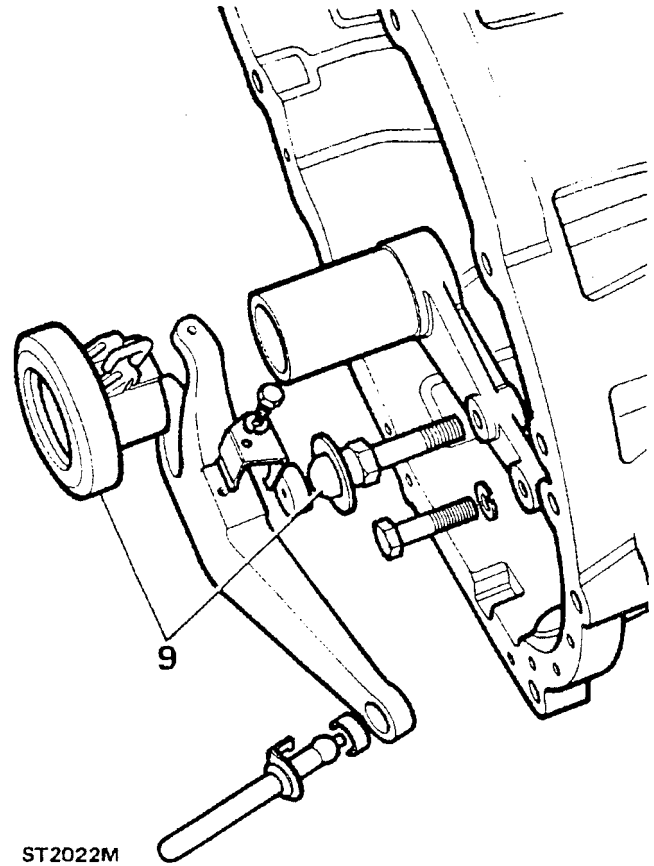

ST2022M

## Input shaft

1. Remove the fourth gear baulk ring and needle roller bearing.

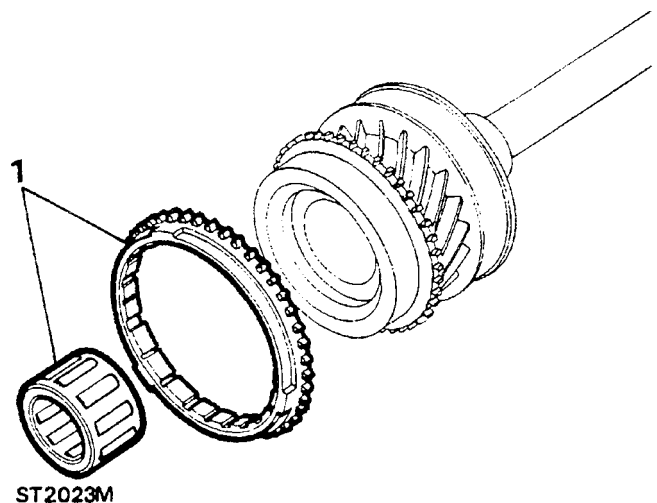

ST2023M

2. Remove the circlip and selective thrust washer.
3. Remove the snap ring from the bearing.



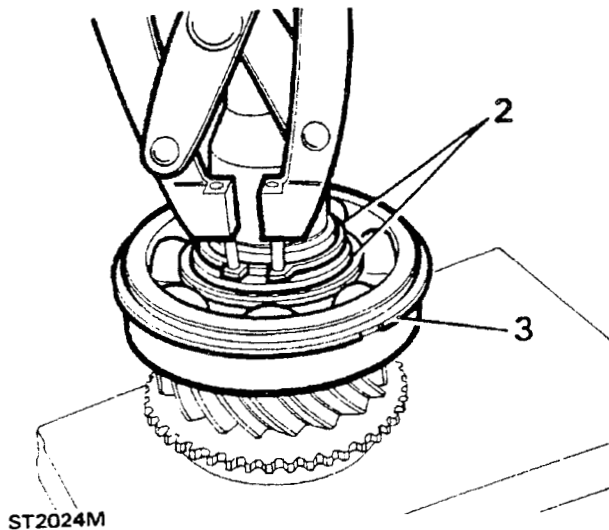

4. Using press MS 47 and two suitable steel blocks, press the input shaft from the bearing.

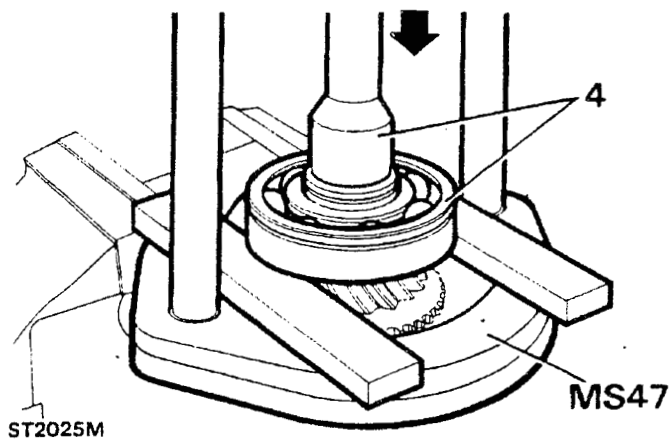

5. Clean all components and ensure that the two oil-ways in the input shaft are clear by blowing through with an air line.

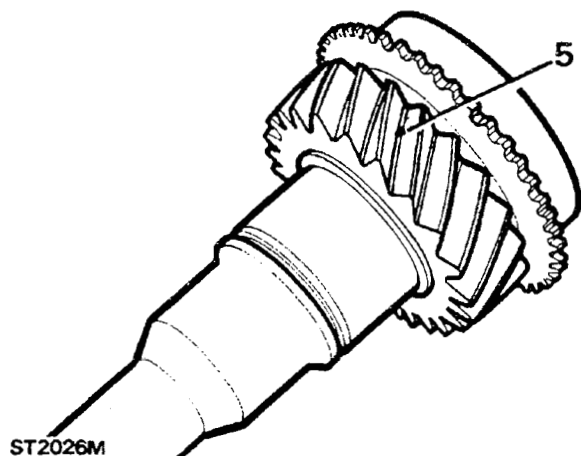

6. Check the input shaft and gear for wear, scores and pits.
7. Using press MS 47 and a suitable tube, fit the input shaft to the bearing with the snap ring groove outwards.

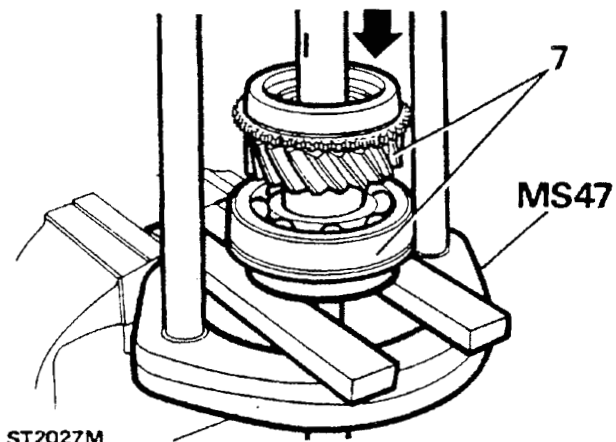

8. Fit the original selective washer and circlip.

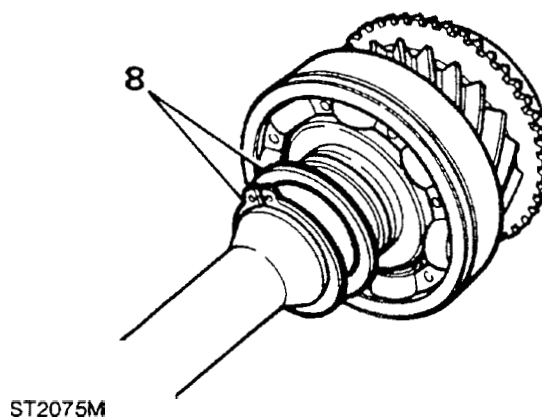

9. Check, with a feeler gauge, the clearance between the bearing and washer. If the clearance is in excess of 0,075mm remove the circlip and washer and select and measure a new washer to take-up the excess clearance.

Continued

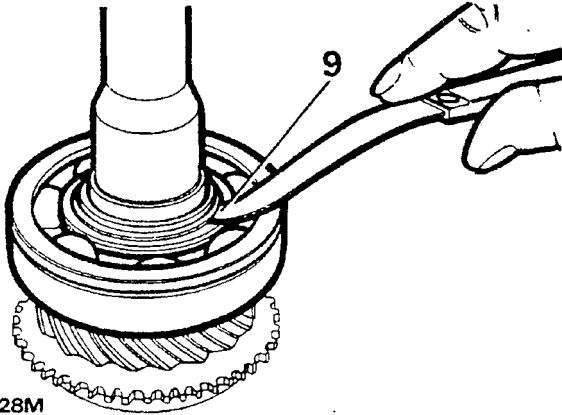

ST2028M

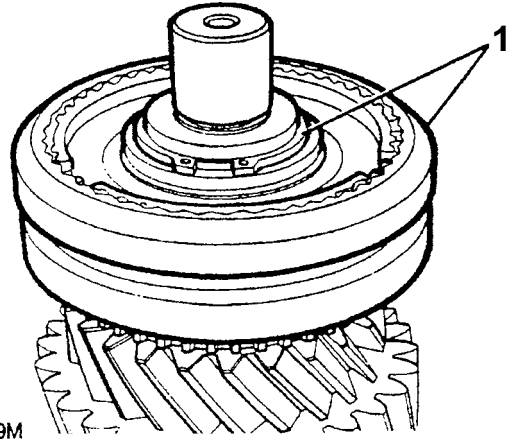

ST2029M

10. Fit the new selective washer, retain with the circlip and recheck that the above clearance is maintained.
11. Lubricate the mainshaft pilot bearing and fit to the mainshaft.
12. Fit the fourth gear baulk ring to the input shaft.
13. Fit the snap ring to the bearing.

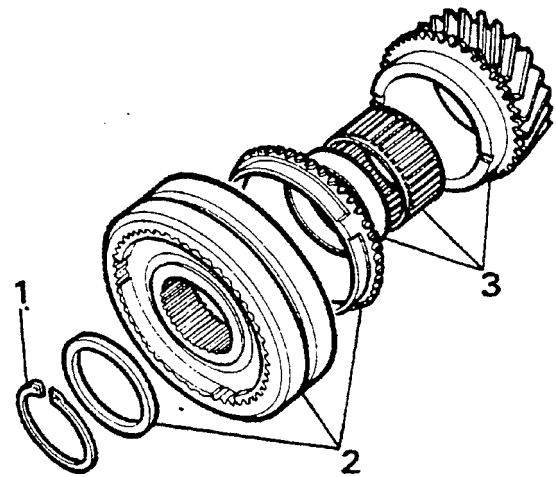

ST2030M

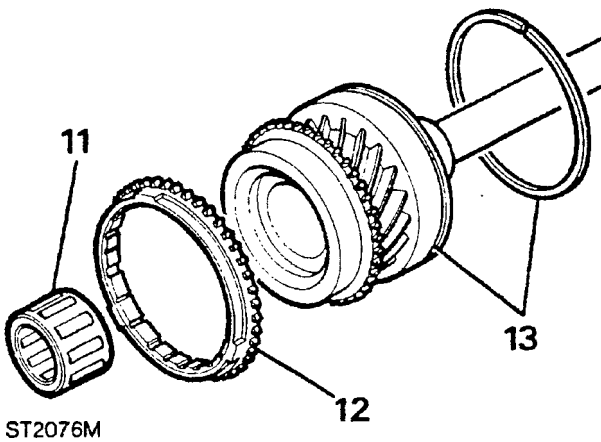

ST2076M

4. invert the mainshaft assembly, in the vice, and remove the mainshaft rear bearing circlip.

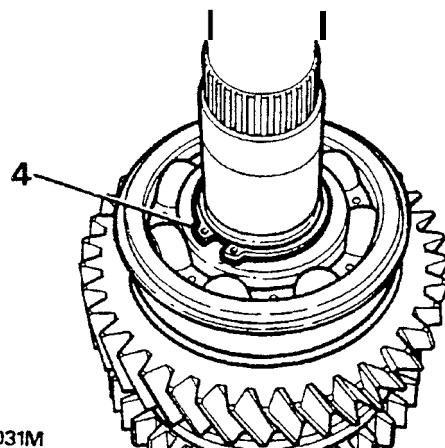

ST2031M

## Mainshaft

1. Secure the mainshaft assembly in a vice and remove the circlip retaining the third/fourth synchrohub and gear assembly.
2. Remove the selective washer, third/fourth synchrohub assembly and baulk ring.
3. Remove the third gear, spacer, and needle roller bearing.

Continued

5. Using press MS 47, and a support under the first gear, press the mainshaft assembly from the rear bearing.

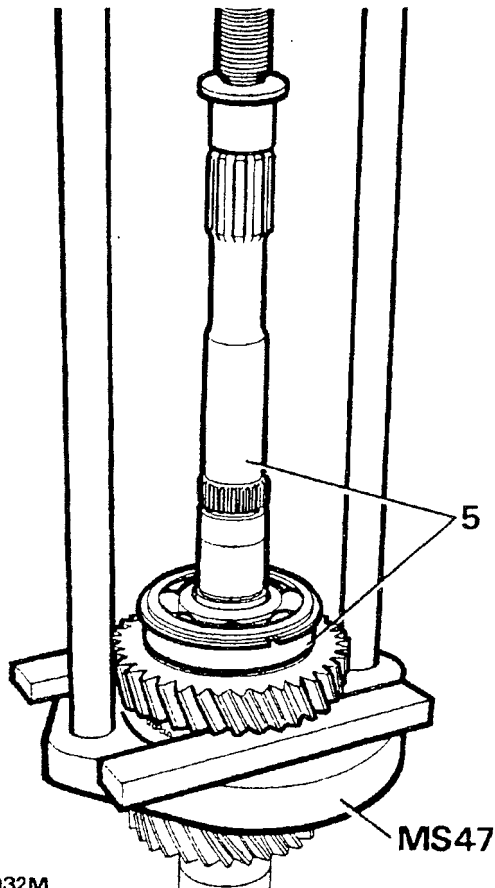

7. In addition remove the remaining items:-

- A. First gear baulk ring.
- B. First and second synchromesh.
- C. Second gear baulk ring.
- D. Second gear spacer.
- E. Second gear needle roller bearing.
- F. Second gear.

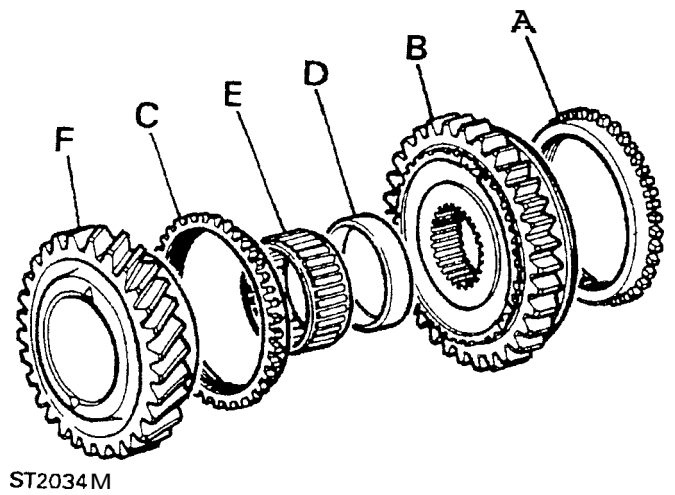

8. Clean the mainshaft and all components and examine for obvious wear.

6. Separate the following components from the assembly:-

- A. First gear.
- B. First gear bush.
- C. Spacer.
- D. needle roller.
- E. Selective washer.
- F. Rear bearing snap ring.

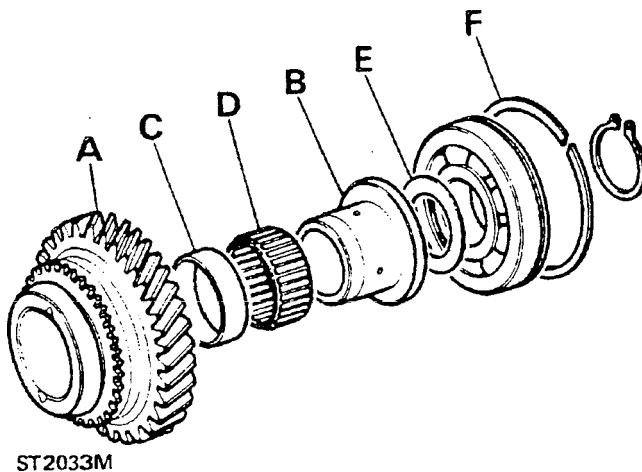

## First/second synchromesh assembly.

1. Before dismantling, mark the relationship of the synchromesh hub to the sleeve.
2. Fit the baulk rings to the synchromesh assemblies to facilitate dismantling and to prevent damage to the springs.
3. Place the synchromesh assembly in a clear plastic bag, to prevent the components being lost and whilst in the bag, press the sleeve from the hub.

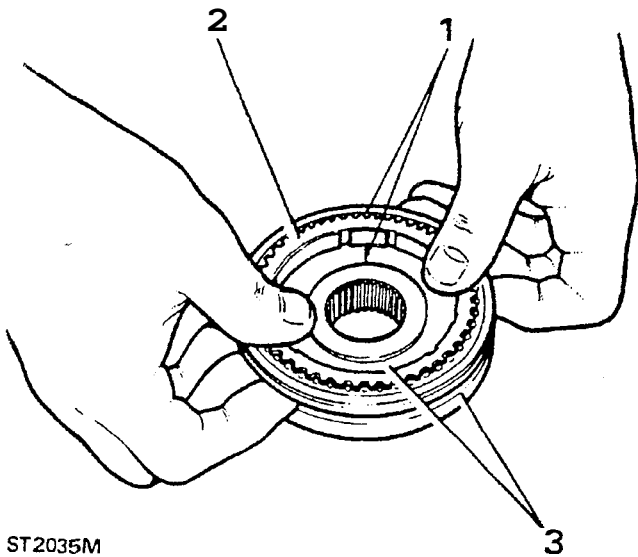

ST2035M

4. Retrieve the synchromesh balls, springs and slipper pads and remove the baulk ring.
5. Clean all the synchromesh assembly components.
6. Before reassembling the synchromesh units carry out the checks for third and second gear end floats as described under the heading "Mainshaft and gear train clearance checks".
7. Fit the synchromesh hub to the sleeve ensuring that the alignment marks line-up.
8. Place the hub and sleeve on a level block.
9. With the hub resting on the block adjust the height of the hub sufficiently to fit the springs.
10. Locate the slipper pads, fit the springs and press the balls down to be retained by the synchromesh sleeve.
11. Fit the baulk ring to the hub and sleeve.

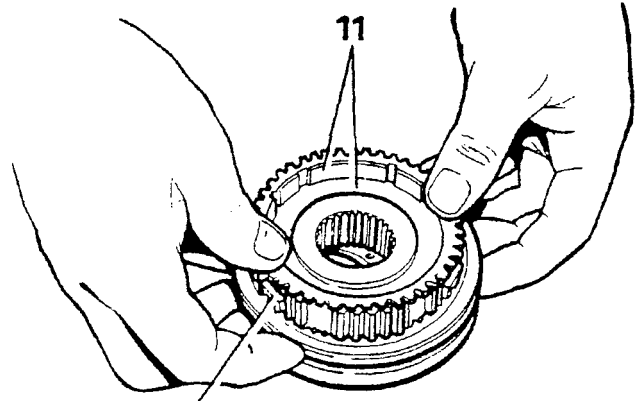

ST1477M 10

12. Carefully invert the synchromesh assembly and fit the second baulk ring.
13. Press the synchromesh sleeve over the hub to locate the balls in position.
14. Remove the baulk rings.

## Third/fourth synchromesh assembly.

1. Repeat the instructions as for the first/second synchromesh assembly but omit the gear end-float checks.
2. when reassembling the synchromesh unit, ensure that the large chamfer on the sleeve faces the small boss on the hub.

## Fifth gear synchromesh assembly.

1. Repeat the instructions relating to the first/second synchromesh assembly.
2. Note that when reassembling the fifth gear synchromesh, the chamfer on the hub, faces to the rear.

**Mainshaft and gears clearance checks.****Running clearances**

Mainshaft 1st gear	0,075mm maximum
Mainshaft 3rd gear	0,075mm maximum
Mainshaft 5th gear	0,075mm maximum
Input shaft bearing	0,075mm maximum

**Third gear end-float.**

1. Locate the mainshaft in a vertical position as shown. Fit the third gear, needle roller bearing and spacer to the mainshaft and replace the third/fourth synchronesh inner member. Press down on the synchronesh inner member and check the gear running clearance with a feeler gauge. A clearance in excess of 0,19mm (0.008ins.) indicates that the thrust faces are worn and may be the cause of gear noise or transmission back-lash. New or little worn components will usually have a clearance of between 0,075mm and 0,125mm (0.003in to 0.005in)

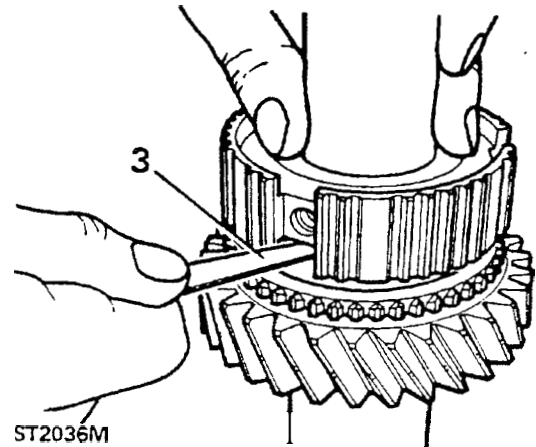
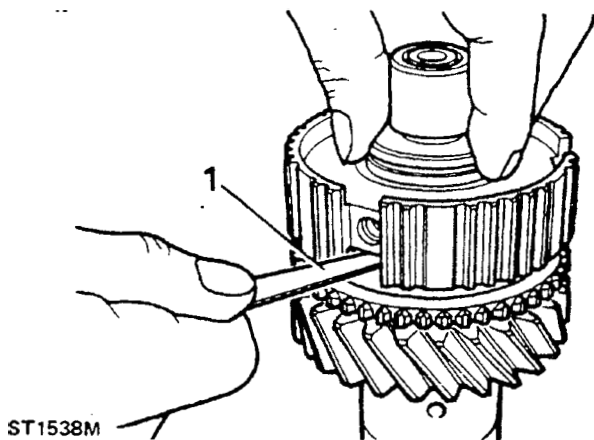

4. Remove the synchronesh inner member and assemble it to the outer member with the slippers, balls and springs.
5. Fit the second gear baulk ring to the mainshaft and the first and second synchronesh hub with the selector groove towards the rear end of the shaft. See items 11 to 17 mainshaft gears, illustration ST2071M page 6.

**First gear to bush end-float.**

6. To carry-out the first gear check, do not assemble the components to the mainshaft. Assemble the spacer, needle bearing and bush to the first gear and using a suitable straight edge or flat plate, check the end float of the first gear on the bush, as shown. The tolerance is the same as for the third and second gears.

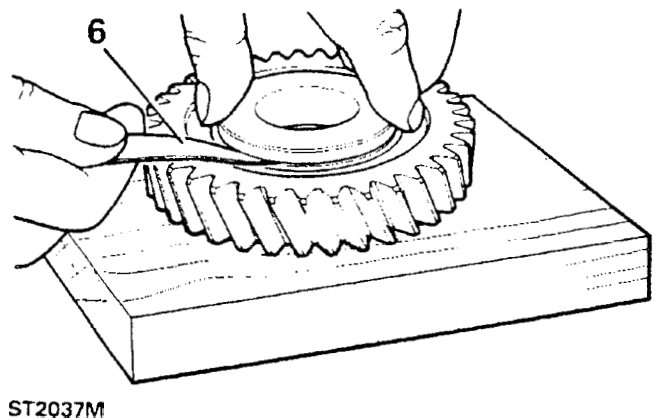
**Second gear end float**

2. Invert the mainshaft for assembly of the rear end components.
3. Fit the second gear needle roller bearing, spacer, Second gear and synchronesh inner member. Press down on the synchronesh inner member and check the second gear end float which is the same as the third gear previously described.

## First/second synchromesh end float.

- Assemble, to the first gear, the spacer, needle roller bearing and first gear bush and fit the assembly to the mainshaft. Fit the original selective washer and dummy mainshaft rear bearing LST 101 and retain with the circlip. With a feeler gauge, check the end-float as shown. Choose a suitable selective washer to obtain a minimum clearance of 0,075mm (0.003ins.)

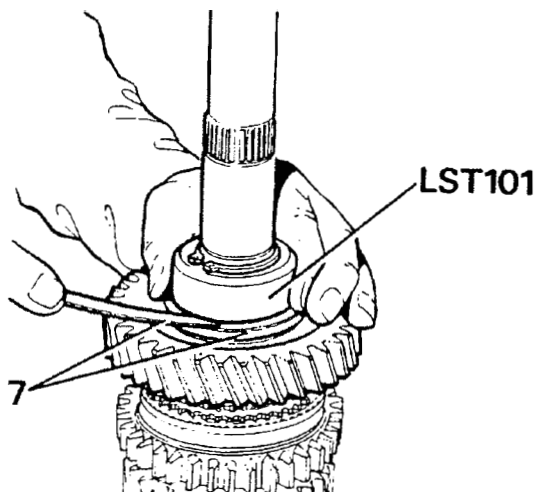

ST2038M

- Remove the dummy bearing and fit the selective washer.
- Start the mainshaft rear bearing squarely on the mainshaft then,

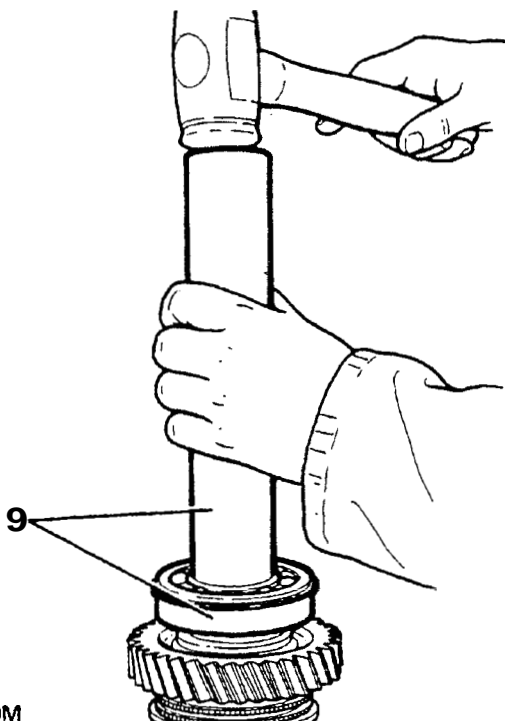

ST2039M

without inverting the shaft, use either a press, capable of accommodating the complete mainshaft assembly, or drive the bearing into position using a suitable tube. Secure the assembly with the circlip.

## Fifth gear end-float.

- Fit the fifth gear thrust washer with the scallop side towards the gear. Fit the fifth gear, needle bearing and spacer followed by the synchromesh assembly, less the baulk ring at this stage. Press down on the synchromesh inner member and check the gear end float, as shown, between the gear and thrust washer. The tolerance is the same as that for the third gear end float.

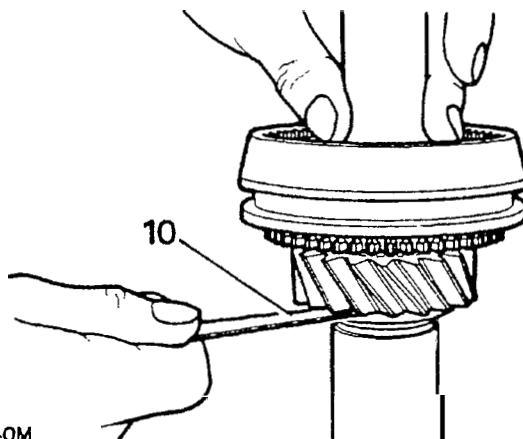

ST2040M

## Third- fourth synchromesh end float.

- Invert the mainshaft to a vertical position, as shown. Fit the third gear needle roller bearing, spacer, third gear, baulk ring and synchromesh with the larger thrust face towards third gear and the chamfer on the outer member towards the front. Fit the original selective washer and retain with the circlip.

Continued

12. Check the clearance between the washer and the synchromesh hub. the clearance must not exceed 0,075mm (0.003ins). The condition is ideal when the selective washer can be just turned by hand.

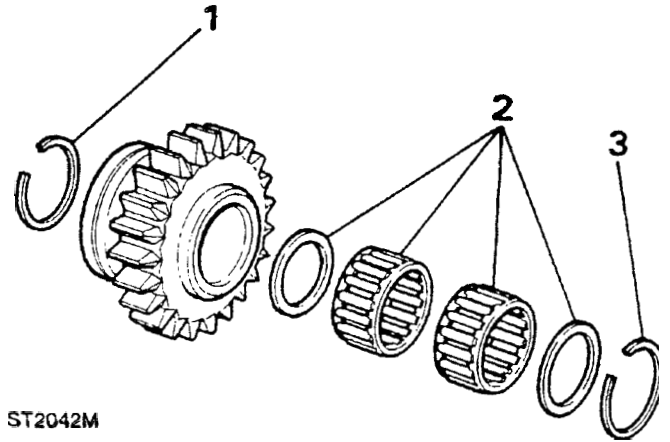
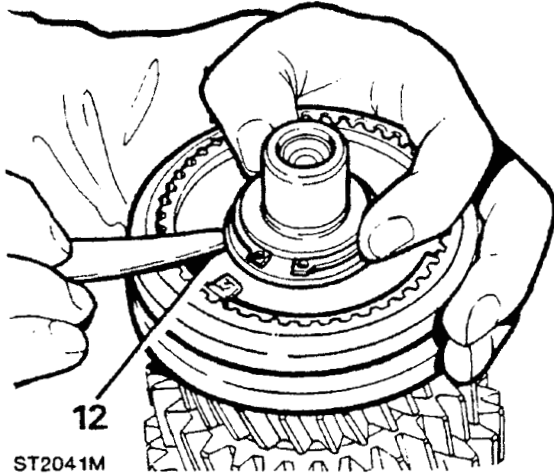

4. If necessary, remove the split pin and withdraw the slipper pads and washer from the reverse gear lever.
5. Press-out the reverse lever cross link pin, if necessary.

**Reverse idler gear, shaft and lever.**

1. Secure the reverse gear in a vice and remove one of the two circlips retaining the bearings.

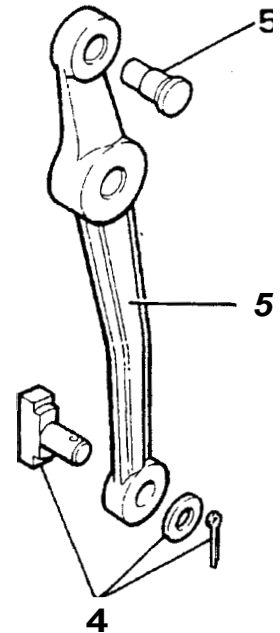
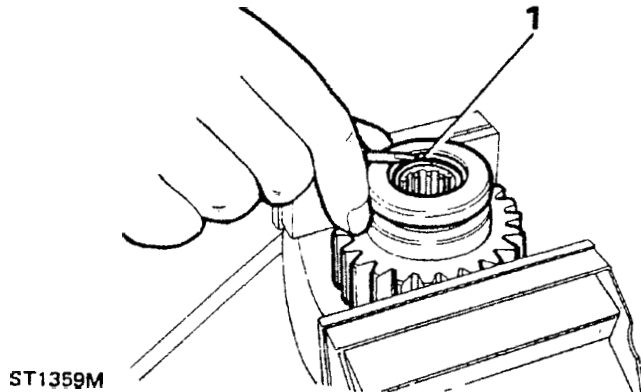

2. Remove the upper thrust washer, two needle roller bearings and lower thrust washer.
3. Invert the reverse gear and remove the second circlip.

## Fifth gear selector fork and bracket.

1. Remove the slipper pads from the selector fork and check for wear.
2. If necessary, remove the circlips and withdraw the pivot pins.
3. Clean all components and refit or renew in reverse order.

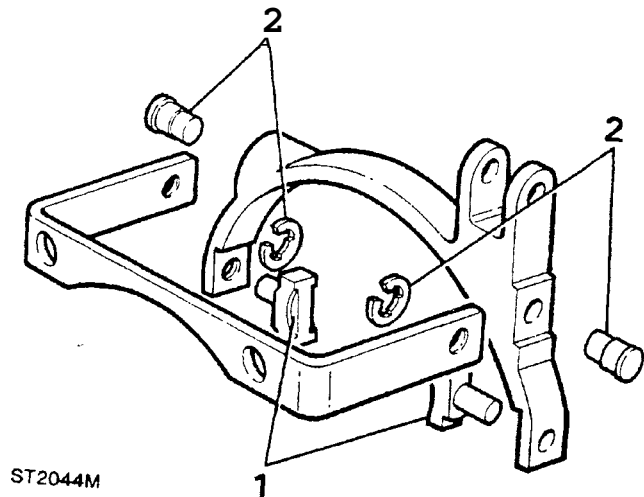

4. Clean the layshaft and bearings and check for wear, pitting and scores.
5. Fit the rear bearing assembly and note that the inner track must be fitted with the identification numbers facing inwards towards the layshaft first gear.
6. Fit the track and outer bearing with the identification numbers facing outwards towards the fifth gear.

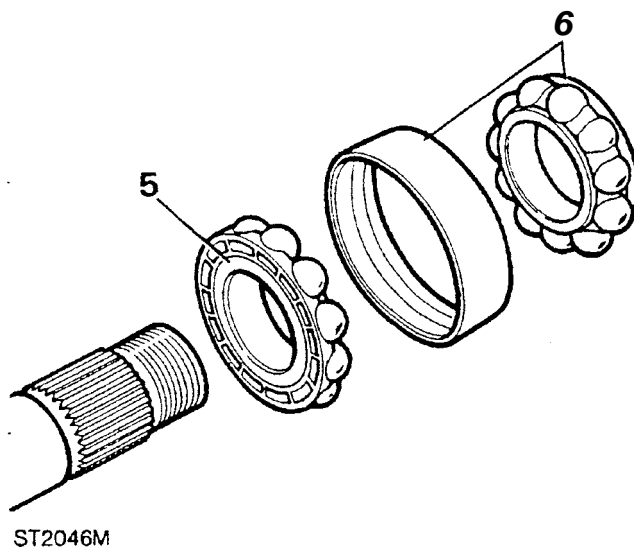

## Layshaft.

1. Remove the stake nut and spacer and withdraw the complete rear bearing.
2. Remove the layshaft front bearing.
3. Secure the layshaft in a vice and lever-off the front bearing inner track.

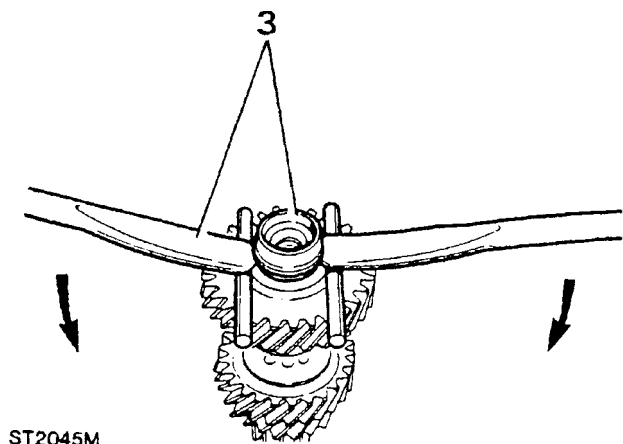

7. Fit the dummy spacer and stake nut loosely to retain the bearing assembly in position on the shaft.
8. Fit the front bearing inner track with the shoulder towards the gear. carefully tap the track squarely into position with a hide mallet.
9. Fit the front bearing race.

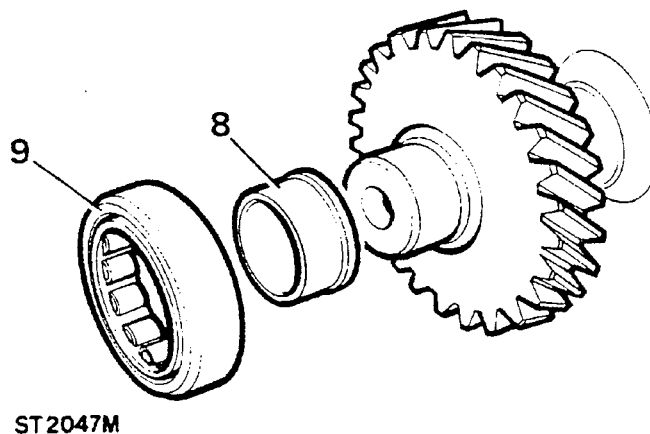



**ASSEMBLE.**

**Fitting reverse idler shaft and gear.**

1. Position the reverse idler gear and thrust washer in the casing with the thrust washer and the chamfer on the thrust washer, towards the gear.
2. Insert the idler shaft into the casing and through into the idler gear and washer. Ensure that the oil pin in the shaft lines-up with the cut-out in the casing, then drive the shaft fully home.

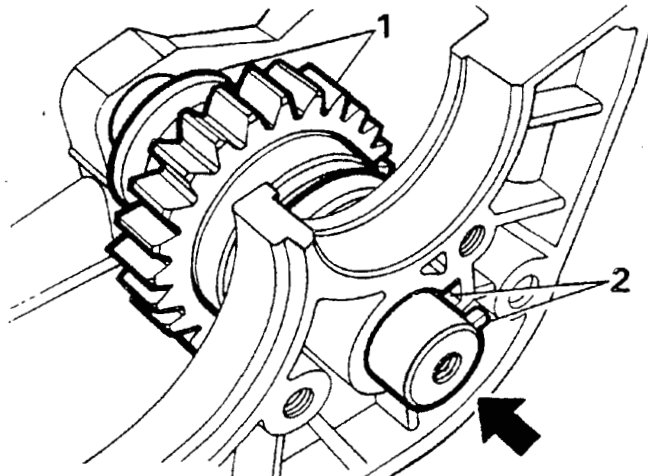

ST 2048M

3. Coat the threads of the reverse lever pivot bolt with Loctite 270 and fit to the casing and tighten to the correct torque.

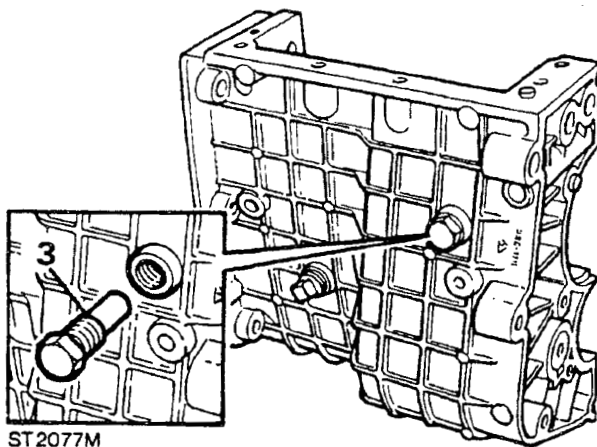

ST 2077M

4. Fit the spacer next to the casing.
5. Fit the lever to the pivot whilst ensuring that the slipper locates in the reverse idler gear groove.

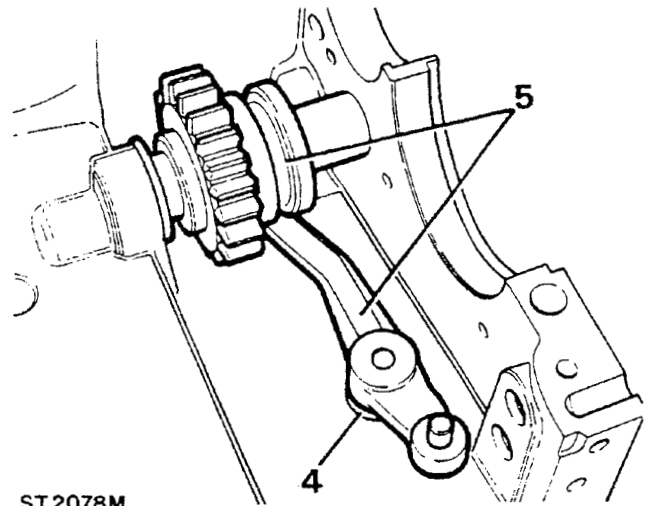

ST 2078M

**Fitting mainshaft and input shaft.**

1. Fit the input shaft to the mainshaft assembly ensuring that the baulk ring engages correctly into the third/fourth synchromesh hub.
2. Lower the above assembly into the gear case noting that the snap ring on the front and rear bearings locate against a shoulder in the casing.

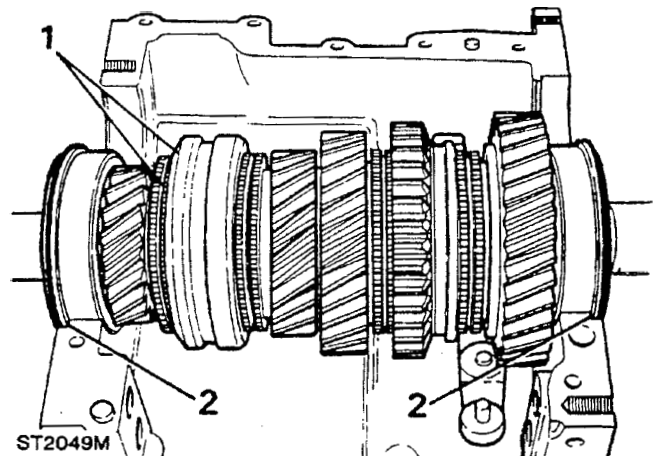

ST 2049M

## Fitting layshaft.

1. Hold the layshaft above the mainshaft assembly and engage the two sets of gears into mesh and roll the layshaft into position in the case. Check that the rear bearing locates against the shoulder in the case.
2. Wipe clean the mating faces of both cases and apply Loctite instant Casket in accordance with the manufacturers instructions.
3. Lower the empty case into position over the gears locating on the dowels.
4. Loosely secure the cases with the seven bolts and tighten evenly to the correct torque 22 to 28 Nm. (16 to 21 lbs.ft.). Clean away any surplus sealant.
5. Refit the stand to the gearbox and secure in the vice.

## Fitting front cover

1. Fit the original shim and spacer to the layshaft front bearing.
2. Fit a new joint washer to the cover and lubricate the oil seal lip.
3. Taking care not to damage the seal lip, fit the cover to the gearbox locating it over the dowels. Secure with the seven bolts and spring washers and tighten evenly to the correct torque.

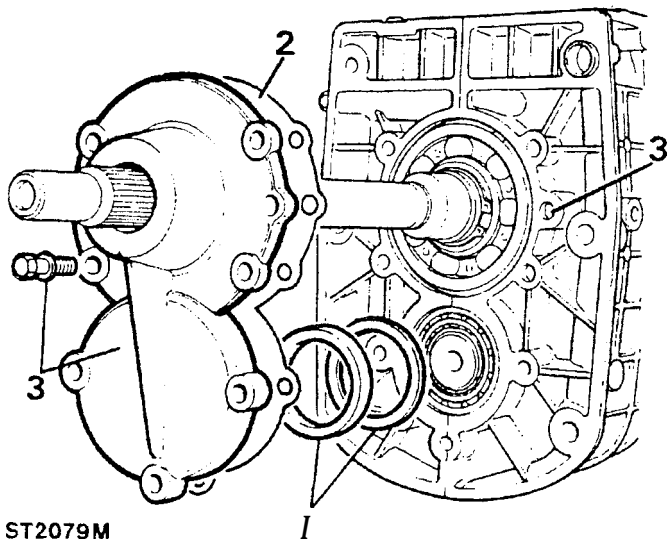

## Fitting rear retainer plate

1. Fit the retainer plate to the gearbox and secure the top of the plate with the two bolts and spring washers.
2. Apply Loctite 270 (stud and bearing fit) to the socket headed screw threads and secure the lower end of the retaining plate.

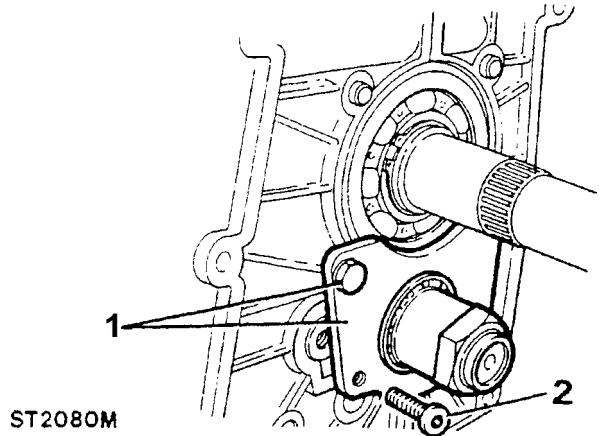

## Fitting layshaft fifth gear.

1. Remove the nut and dummy spacer from the layshaft.
2. Fit the fifth gear to the layshaft with the large boss to the rear.
3. To facilitate the next instruction, lock the gearbox by engaging first and fourth gears.
4. Fit a new fifth gear retaining nut and tighten to the correct torque. Do not stake the nut at this stage.

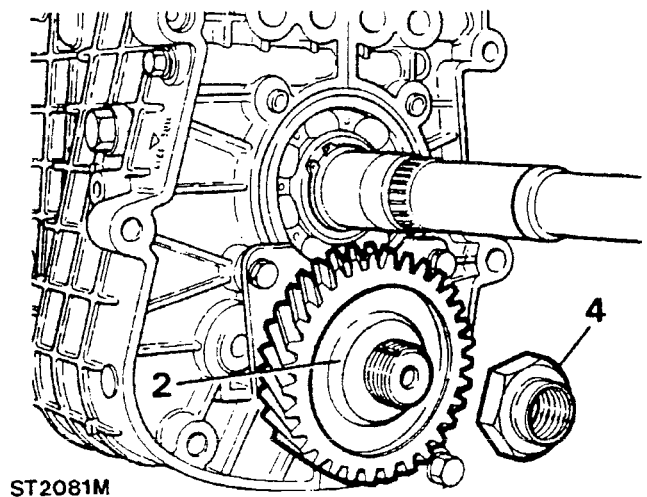

5. Disengage the first and fourth gears.

**Fifth gear synchromesh end float.**

1. Fit the thrust washer, grooves outwards, towards fifth gear.
2. Lubricate and fit the needle roller bearing to the mainshaft.
3. Fit the spacer and fifth gear.

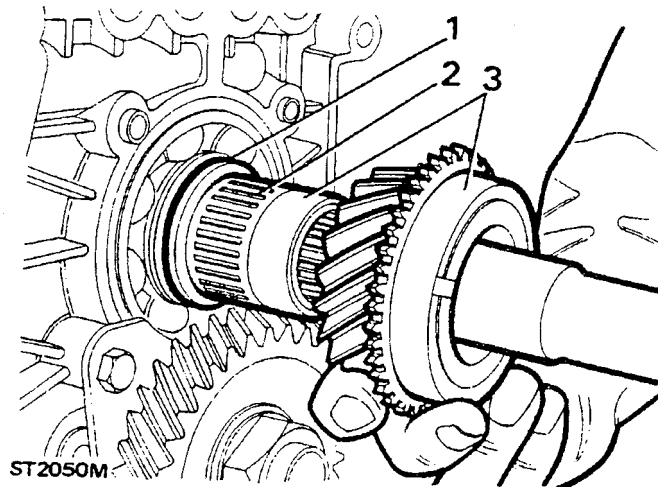

4. Fit the fifth gear synchromesh cone and hub assembly.
5. Fit the fifth gear synchromesh hub retaining plate, peg outwards.
6. Omit the "O" ring and fit the sleeve with the slot over the peg.
7. Fit the original selective washer and retain with the snap ring.

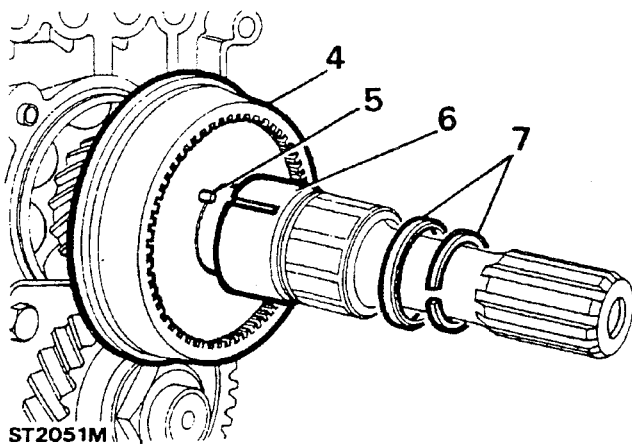

8. Using a feeler gauge, measure the clearance between the washer and the sleeve. If necessary exchange the washer for one that will provide a clearance of 0,075mm (0.003ins.)

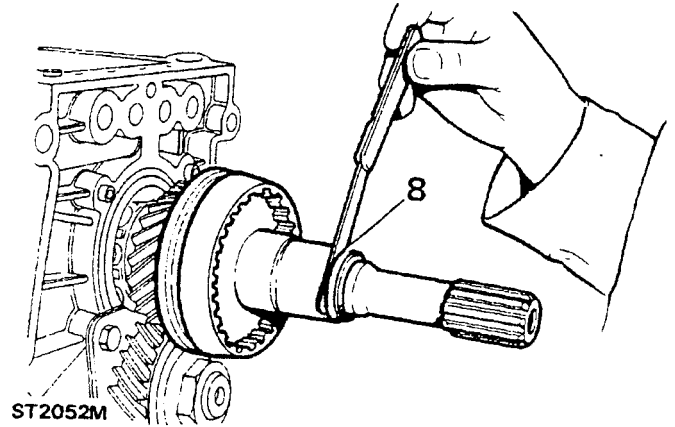

9. Remove the snap ring, selective washer and sleeve.
10. Wind protective tape round the mainshaft splines and fit the "O" ring seal against the synchromesh hub retaining plate.

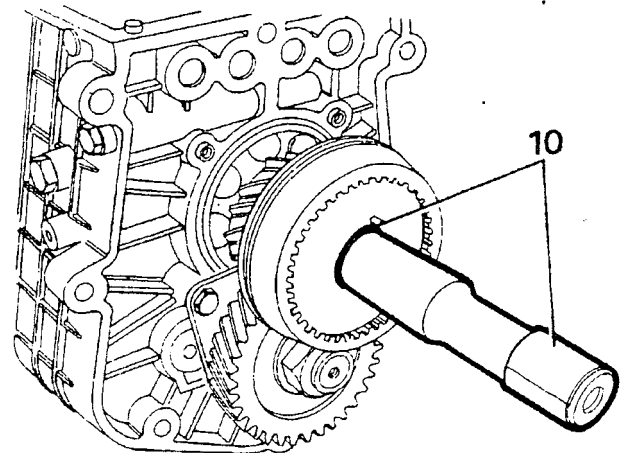

11. Refit the sleeve, selective washer and snap ring and remove the protective tape.

## Fitting selector rails and forks.

1. Locate the fifth gear fork and bracket on to the synchromesh hub and gearbox dowels.
2. Secure the fork bracket to the gearbox with two bolts and plain washers.

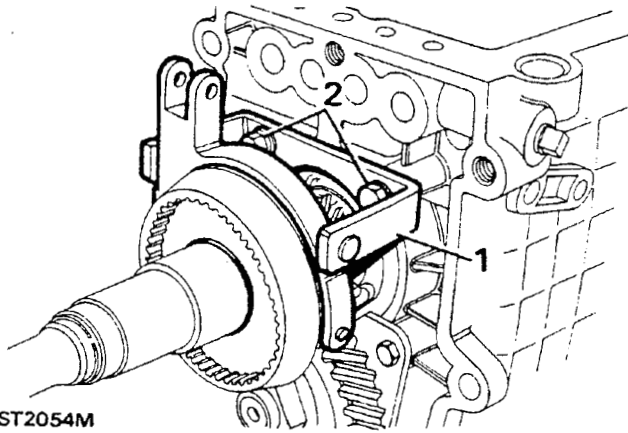

ST2054M

3. Fit the selector rail interlock plungers to the gearbox case.

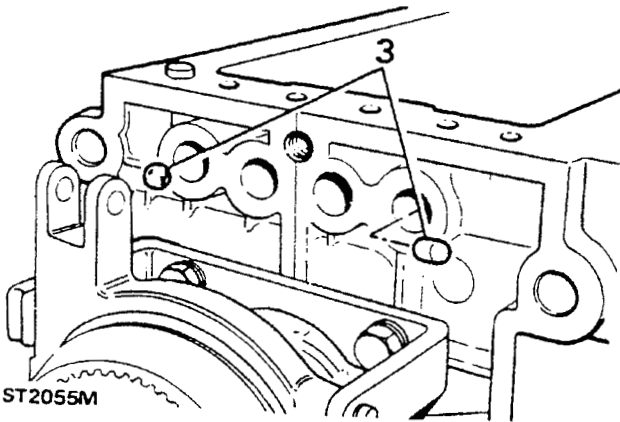

ST2055M

4. Fit the first/second and third/fourth selector forks.

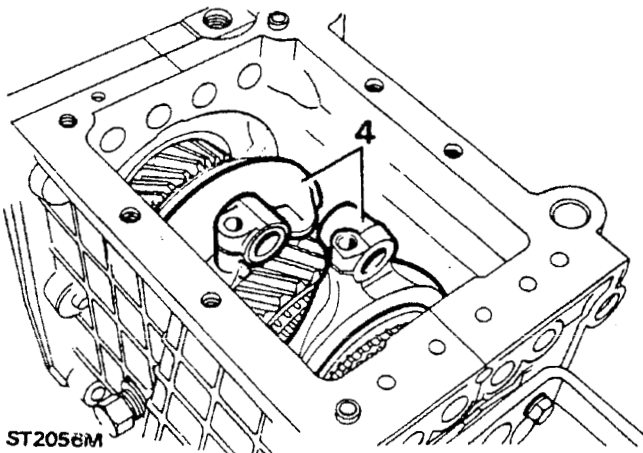

ST2056M

5. Place the reverse gear cross-over lever in position in the gearbox locating the fork end over the reverse lever operating pin.
6. insert the interlock plunger into the first/second selector rail.

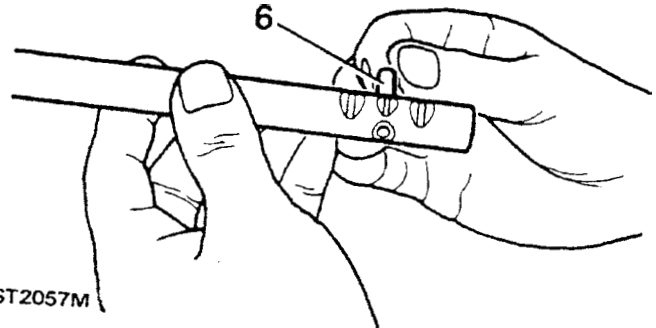

ST2057M

7. Push the first/second selector rail into the gearbox and locate in the reverse cross-over lever and selector fork. Do not tighten the fork clamp bolt at this stage.

**Note: the first/second fork clamp bolt is not a set bolt unlike the third/fourth fork clamp bolt.**

8. Fit the first/second selector jaw to the rail and align to accept the retaining roll pin.
9. Using a suitable drift, tap-in the roll pin to secure the jaw and rail.
10. Repeat instruction 9 for the third/ fourth selector rail and jaw.
11. Push the fifth gear selector rail through the gearbox and the reverse cross-over lever.
12. Fit the fifth gear selector jaw to the rail and align to accept the roll pin.
13. Locate the selector rail into the fifth gear selector fork and secure with the clevis pin, washer and split pin.
14. Secure the jaw to the fifth gear selector rail with the roll pin.
15. Push the reverse selector rail through the gearbox and reverse cross-over lever but do not tighten the lever clamp bolt at this stage.

Continued

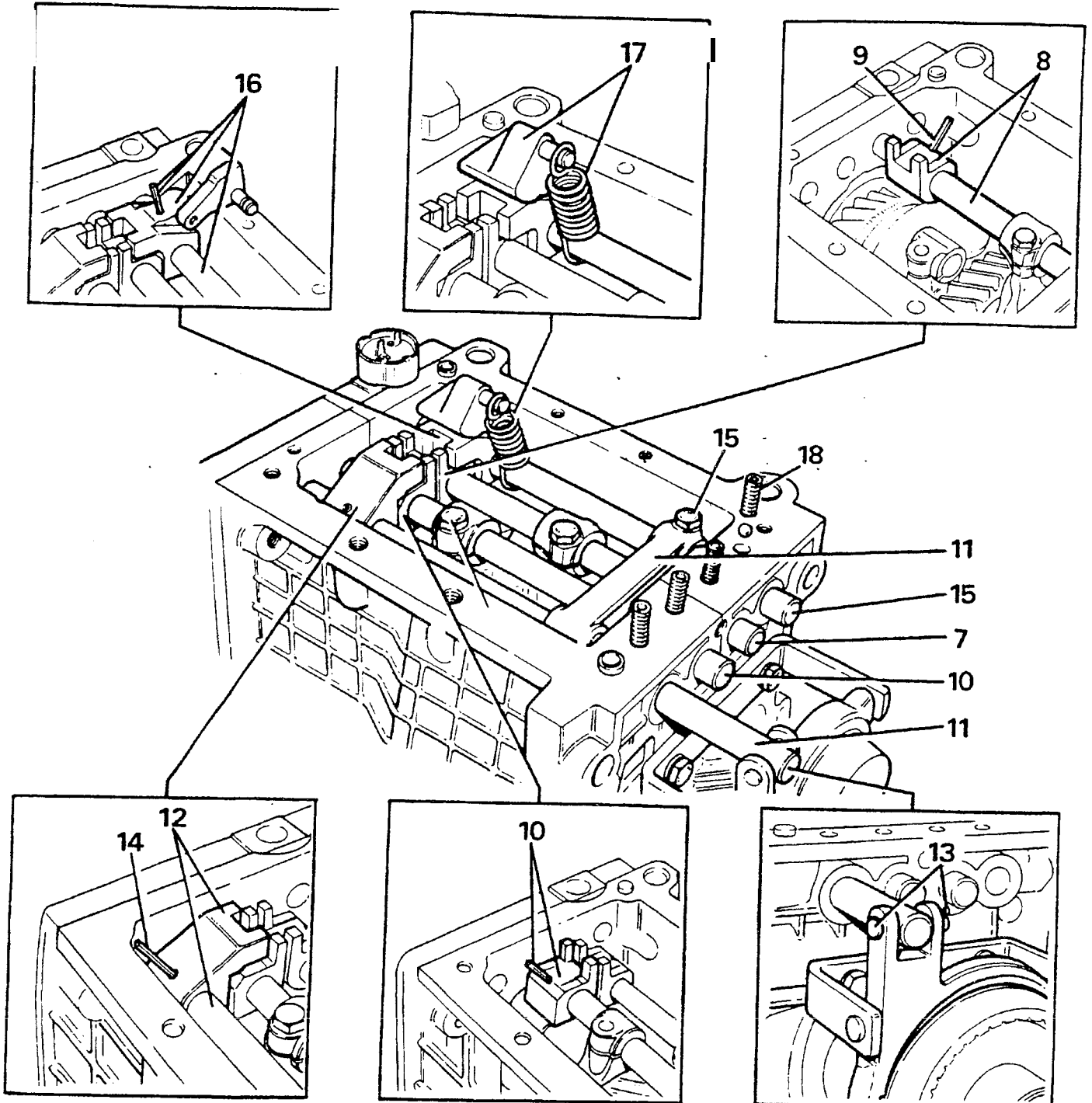

ST2058M

16. Fit the **jaw** to the reverse selector rail, align the holes, and secure with the roll pin using a suitable drift. The pin must be inserted so that it is flush with the underside of the jaw to ensure that the jaw is adequately retained.
17. Fit the reverse gate spring to the selector rail and knock-over lever.
18. Fit the detent balls and springs.

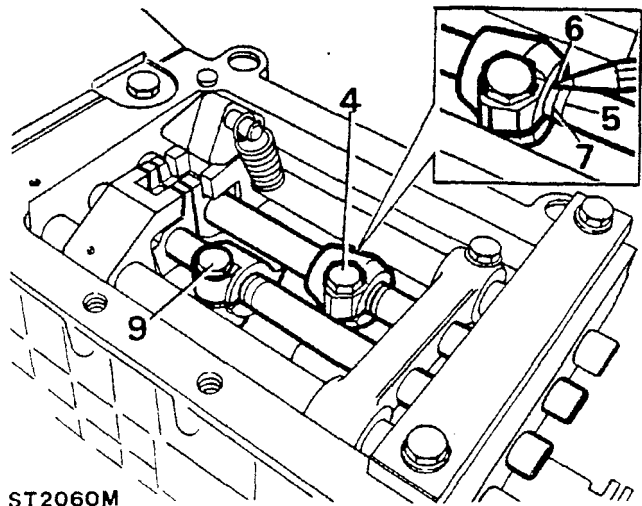

ST2060M

9. Repeat instructions 4 to 8 to adjust the third/fourth selector fork and rail.

### Selector fork adjustment.

1. Fit the top cover gasket.
2. Secure the detent spring retaining tool and spacers (manufactured tool) to the gearbox with two 8 x 50mm bolts and plain washers.

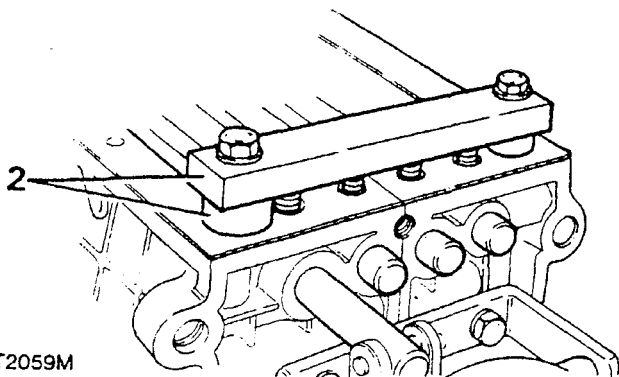

ST2059M

3. Tighten the bolts to compress the detent springs until the retaining plate contacts the two spacers.
4. Ensure that the first/second selector rail and synchromesh sleeve are in the neutral position. Tighten the clamp bolt sufficiently to eliminate any rock in the selector fork and move the selector fork rearwards.
5. Scribe a pencil line on the rail at the rear of the fork yoke.
6. Move the fork forwards, to the original position and scribe another line at the rear of the yoke.
7. Now scribe a line midway between the two lines on the selector shaft.
8. Move the selector fork rearwards so that the yoke coincides with the centre line and tighten the clamp bolt.

### Reverse cross-over lever adjustment.

The purpose of the following adjustment is to ensure that when first gear is selected the outer member of the first/ second synchromesh unit is not also engaged with the reverse idler gear.

1. Move the reverse idler gear thrust washer fully forward.
2. Fit the manufactured gauge to the reverse idler gear shaft so that it is between the idler gear and thrust washer.
3. Move the reverse gear selector rail rearwards to engage reverse gear.
4. Move the cross-over lever rearwards to lightly nip the gauge between the reverse gear and thrust washer.
5. Tighten the reverse cross-over lever clamp bolt and return the selector rail to the neutral position and remove the gauge.
6. Move the first/second selector rail rearwards to select first gear.

**Continued**

7. Check that a minimum clearance of 1,0mm exists between the front face of the reverse idler gear and the rear face of the reverse gear on the first/second synchromesh sleeve. If the clearance is insufficient, adjust the cross-over lever again.
8. Return the first/second selector rail back to neutral.
9. Remove the detent spring retaining tool and spacers

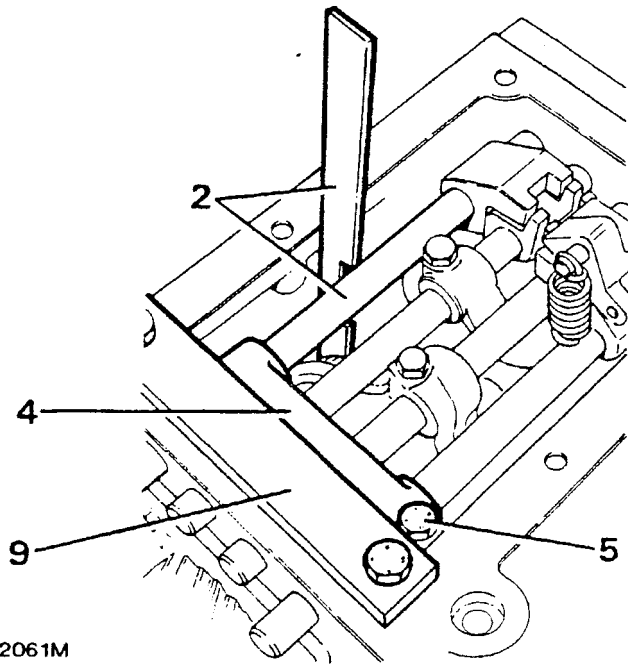

ST2061M

**Gearbox top cover.**

1. Fit the top cover gasket.
2. Fit the top cover locating it over the detent springs.
3. Position the breather pipe, locate retaining clips and secure the top cover with the eight bolts and spring washers.
4. Fit the breather pipe banjo union and fibre washers.
5. Fit the reverse light switch.
6. Place clean rag in top cover gear lever aperture to prevent the entry of dirt.

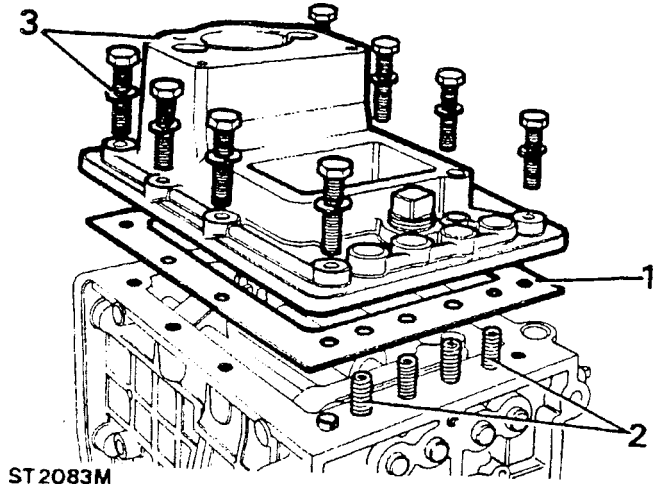

ST2083M

**lower gear lever and bias spring housing**

1. Remove the rag from gearbox top cover.
2. Lubricate and fit the gear lever ball lower yoke and nylon cup.
3. Fit a new gasket to the housing.
4. Fit the rubber grommet.
5. Apply grease to the bias springs.
6. Fit the shims and bias springs, followed by the spring housing.
7. Secure with the four set screws and spring washers.

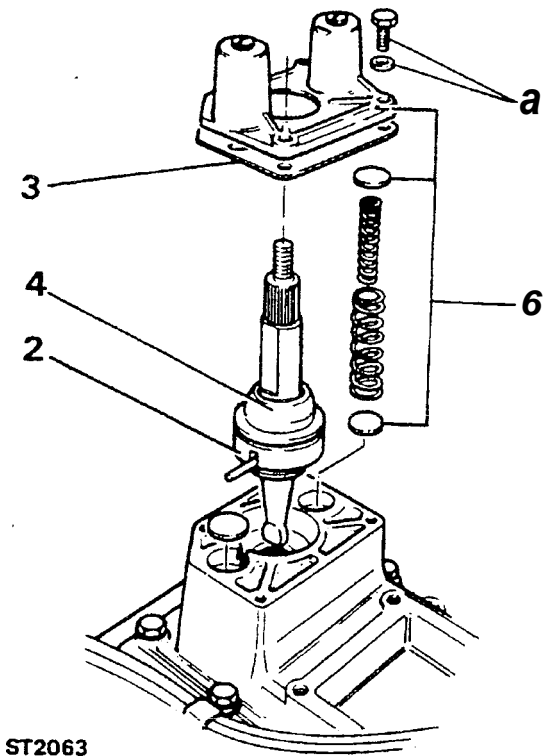

ST2063

## Bell housing.

1. Fit a new bell housing gasket.
2. Locate the bell housing squarely on the dowels and secure to the gearbox with the six bolts and spring washers.

## Gearbox extension housing.

1. Remove the gearbox assembly from the vice and detach the stand.
2. The special nut retaining the fifth gear to the layshaft must be secured by carefully forming the collar of the nut into the layshaft slots, as illustrated.

**CAUTION:** A round nose tool must be used for this operation to avoid splitting the collar of the nut. Also, the layshaft fifth gear should be supported by a block of timber whilst the nut is being deformed to prevent damage to the adjacent bearing.

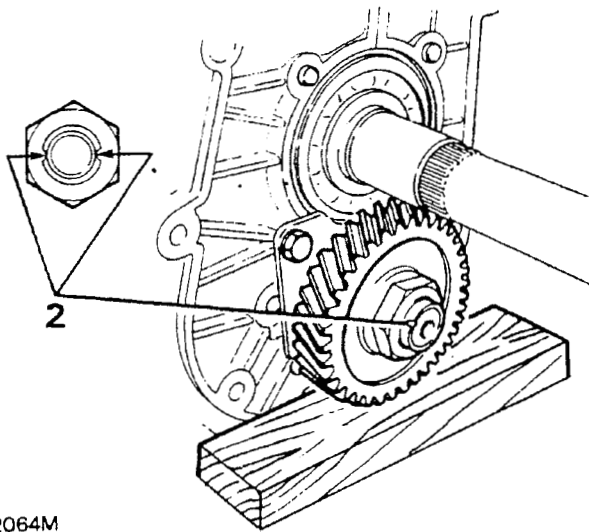

ST2064M

3. Support the underside of the gearbox with a block of timber.
4. Lubricate the oil seal protection sleeve LST 102 and insert it into the oil seal from inside the extension housing.
5. Fit a new gasket to the extension housing.

6. Carefully slide the extension housing, with the seal protection sleeve in position, over the mainshaft and locate on the dowels.

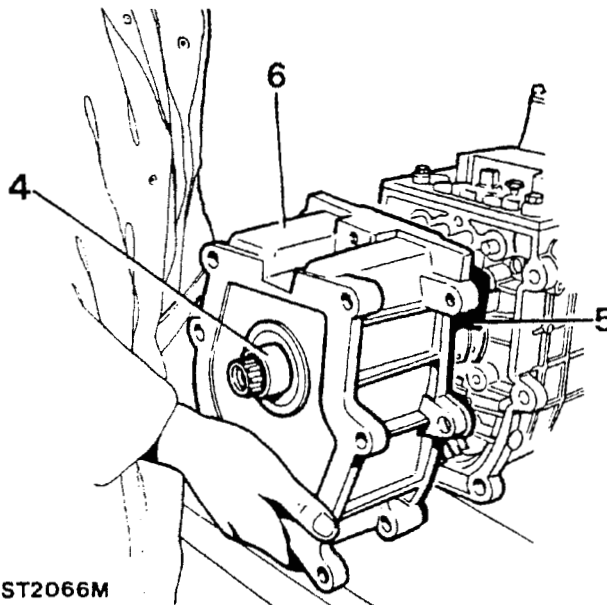

ST2066M

7. Withdraw the oil seal protection sleeve.
8. Secure the extension housing with the eight bolts, spring washers and single nut. The illustration below shows the correct length of bolt for each of the eight locations.

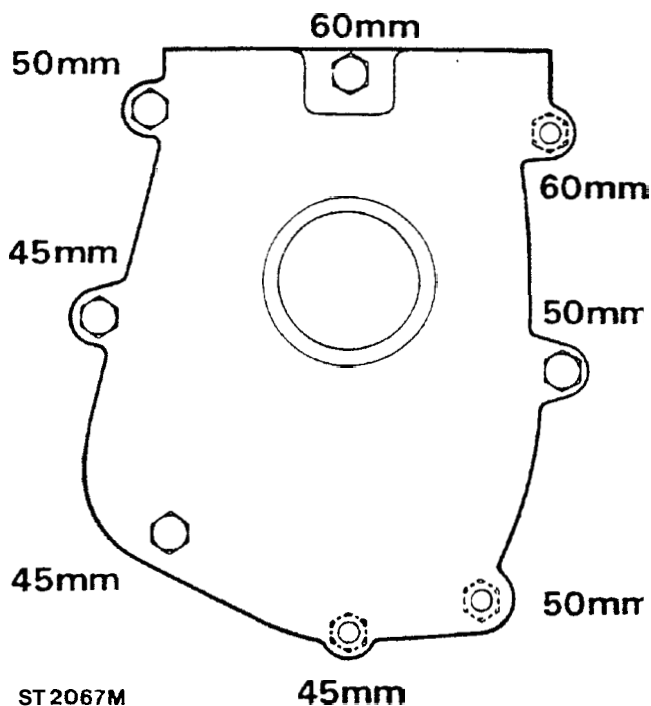

ST2067M



**Third/fourth selector rail adjustment**

1. Slacken the third/fourth stop screw in the extension housing.

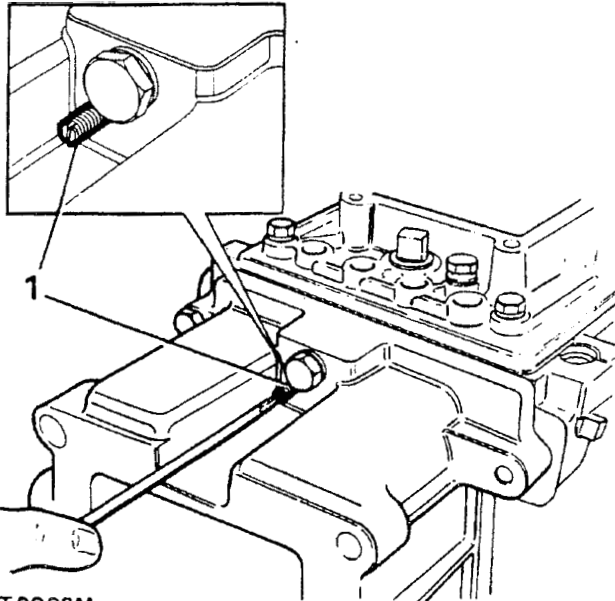

2. Select third gear.
3. Tighten the stop screw until it makes contact with the third/fourth selector rail.
4. Turn back the stop screw one turn.
5. Return the gear lever to the neutral position.
6. Slacken the locknut on the third/fourth stop bolt inside the bell housing.

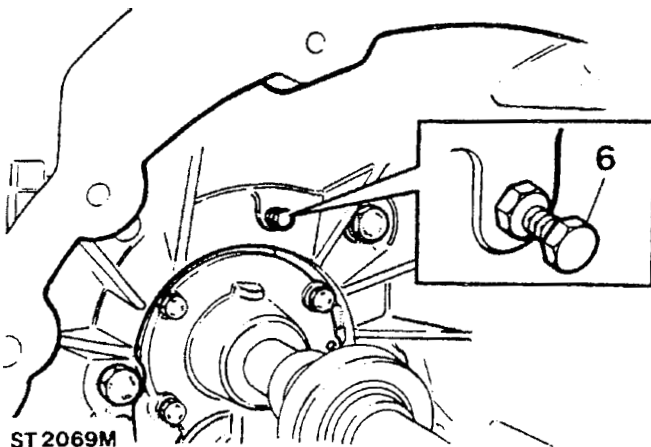

7. Unscrew the stop bolt.
8. Select fourth gear and screw-in the stop bolt until contact is made with the third/fourth selector shaft.
9. Turn back the stop bolt one turn and tighten the locknut.
10. Return the gear lever to the neutral position.

**Bias spring adjustment.**

1. Apply Loctite stud and bearing fit 270 to the bias spring screws and turn the screws clockwise until the heads are flush with the top face of the bias spring housing.

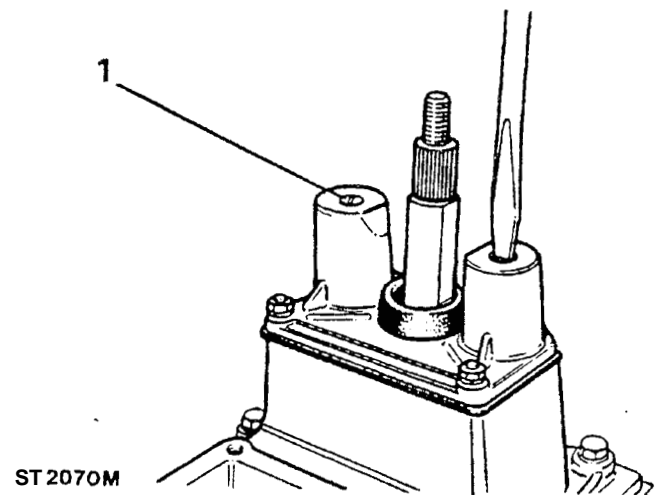

**Gearbox mounting**

1. Fit the mounting to the extension housing and secure with the four bolts.

